



إدارة المناهج والكتب المدرسية

Action Pack

2

**Second Grade
(New Edition)**

Activity Book

Liz Kilbey

The Ministry of Education has decided to adopt this book for Jordanian school in accordance with the approval of the board of education decision No. 3/2011 in its meeting on 9/6/2011 for the 2011/2012 academic year

All rights reserved to the Ministry of Education

Evaluation and Adaptation Committee

Dr. Hamza Ali Al-Omary

Dr. Saleh Hassan Al-Omary

Dr. Hussein Mohammad Yagi

Haifa Hafez Takrouri

Dr. Tha'er Issa Tawalbeh

Narmin Dawod Al-Azza

Nuha Sulaiman Al-Tarawneh

Production: Dr. Haroun Abd Al Jaleel Ali

Proofreader: Dr. Adnan Ahmad AL-Omari

Reviewer: Dr. Manal Fahed Abu Rumman

ISBN: 978-614-406-182-4

Printed 2011

Reprinted 2012-2024

Contents

First semester

UNIT 1	Good morning, children	4
UNIT 2	Where do you live?	6
UNIT 3	What day is it today?	8
UNIT 4	Review	10
UNIT 5	What can you see?	11
UNIT 6	Can turtles swim?	13
UNIT 7	I've got a headache	15
UNIT 8	Review	17

Second semester

UNIT 9	How many are there?	18
UNIT 10	What time is it?	20
UNIT 11	What does he look like?	22
UNIT 12	Review	24
UNIT 13	This is a present for you	25
UNIT 14	I like playing tennis	27
UNIT 15	How do you spell it?	29
UNIT 16	Review	31

1. Match

1.

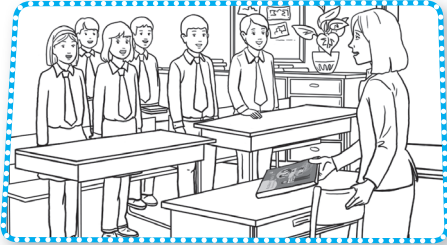

a.

Look at the board, please.

2.

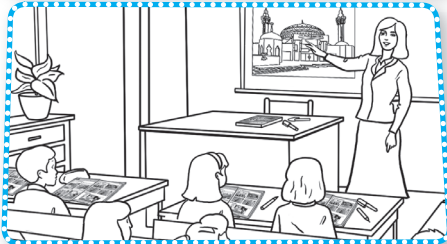

b.

Good morning, children.
Good morning, Miss Rasmi.

3.



c.

Open your books, please.

2. Look and copy

books, children, board

1. Good morning, children.

2. Open your books.

3. Look at the board, please.

3. Listen and say

Yes, it is.

No, it isn't.

1.

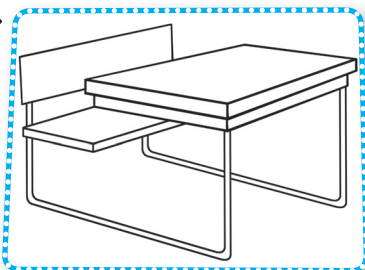

2.

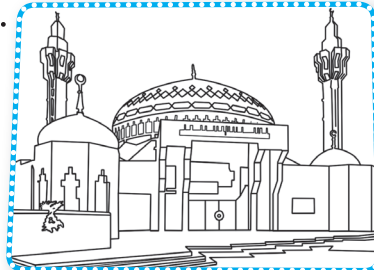

3.

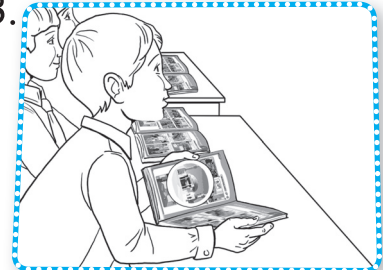

4. Match, trace and copy

M

J

R

r

j

m

mosque, Jordan, ruler

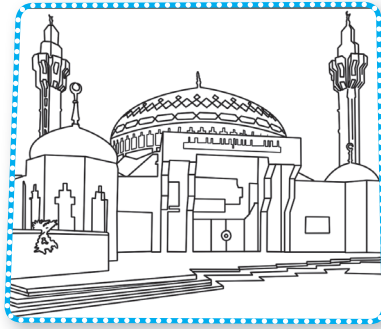
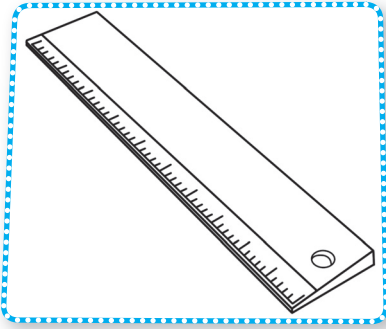

1. A ruler

2. A _____

3. _____

5. Look, circle and say

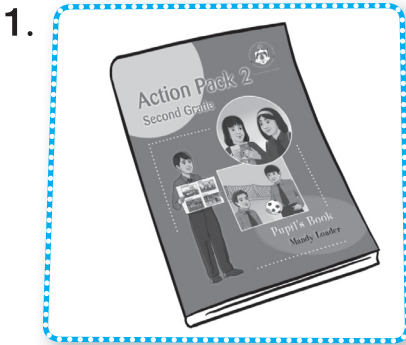

Is it a book?

Yes, it is. / No, it isn't.

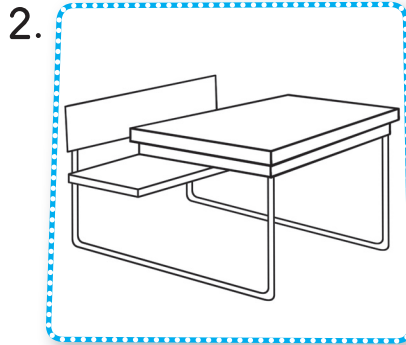

Is it a pencil case?

Yes, it is. / No, it isn't.

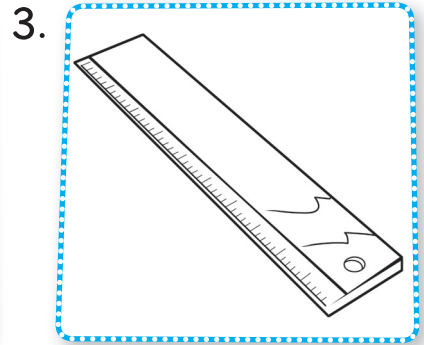

Is it a ruler?

Yes, it is. / No, it isn't.

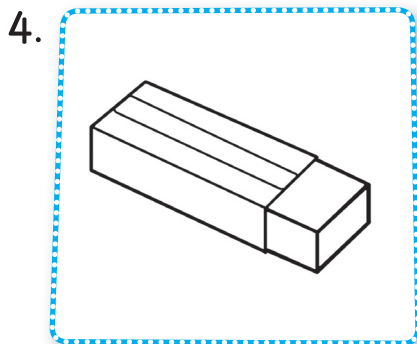

Is it a rubber?

Yes, it is. / No, it isn't.

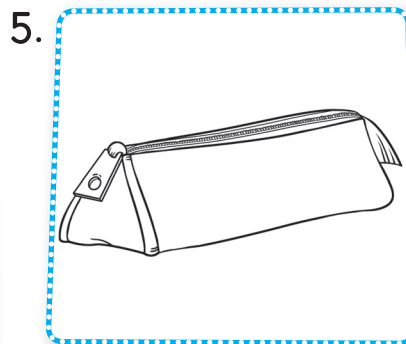

Is it a desk?

Yes, it is. / No, it isn't.

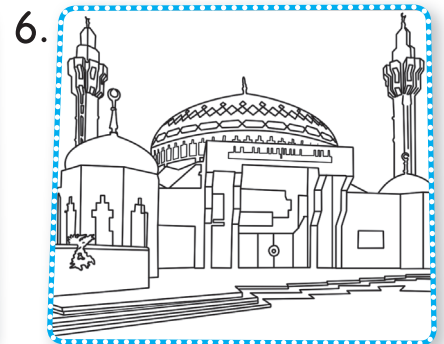

Is it a mosque?

Yes, it is. / No, it isn't.

1. Draw, colour and write

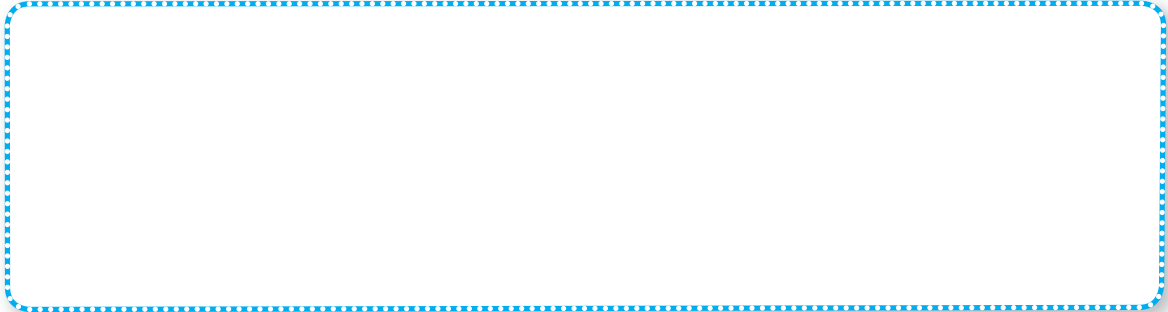

This is me. I live in _____.

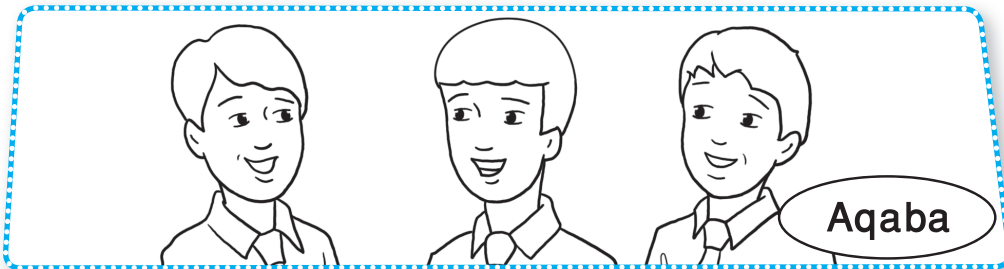
2.  Listen and circle

1. Where *do/does* he live? He *live/lives* in Aqaba.

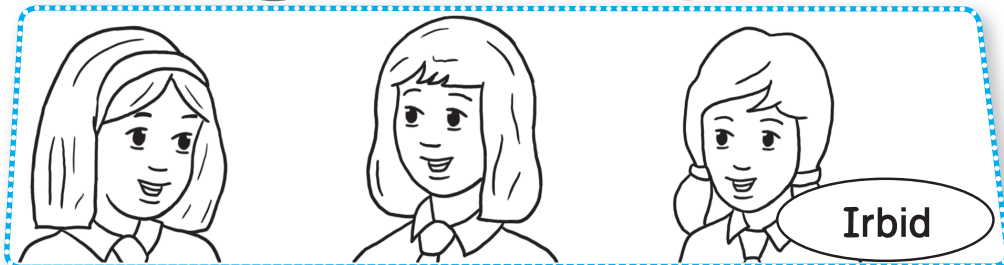

2. Where *do/does* she live? She *live/lives* in Irbid.

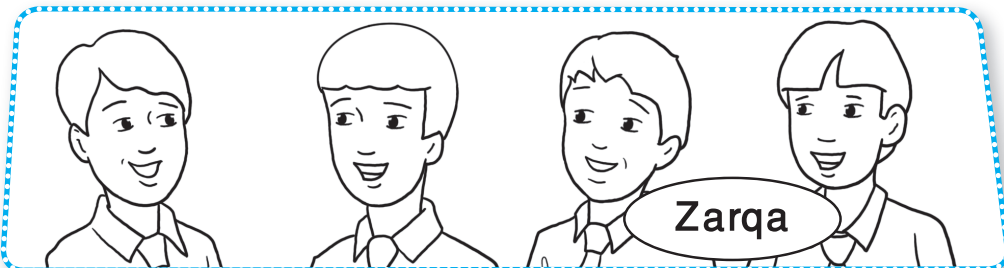

3. Where *do/does* they live? They *live/lives* in Zarqa.

3. Look and write

grandma, grandpa, cousin, aunt, uncle

3. _____

5. _____

4. _____

2. _____

1. grandpa

That's my ...

4. Trace and write

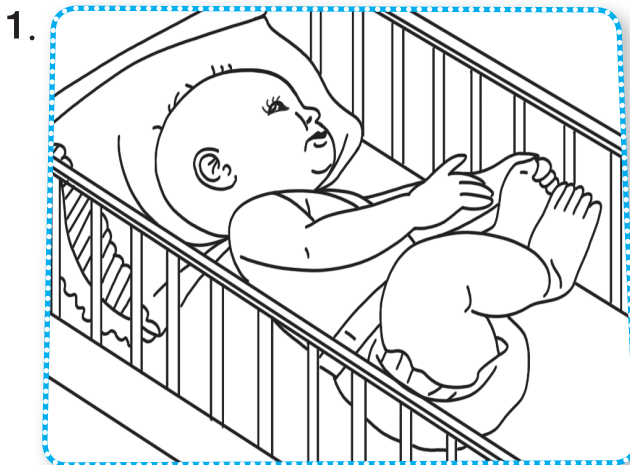

baby

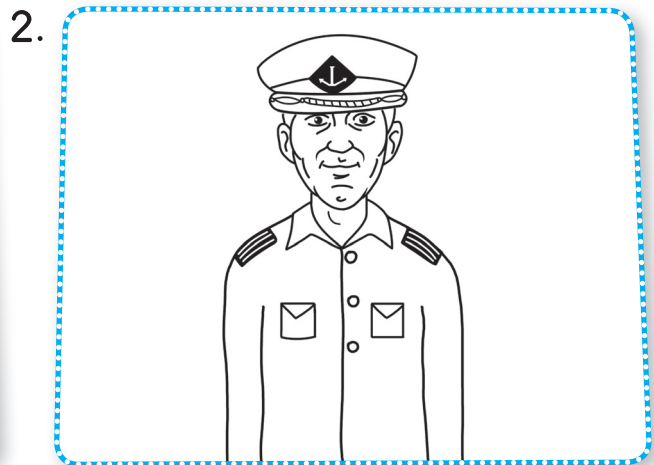

uncle

1. Say and write

Sunday

Monday

Tuesday

Thursday

Saturday

2.  Listen and circle

SUNDAY	MONDAY	TUESDAY	WEDNESDAY	THURSDAY	FRIDAY	SATURDAY
1	2	3	4	5	6	7
8	9	10	11	12	13	14
15	16	17	18	19	20	21
22	23	24	25	26	27	28
29	30	31				

1. It's Tuesday / Sunday.
2. It's Monday / Wednesday.
3. It's Saturday / Thursday.
4. It's Friday / Tuesday.
5. It's Wednesday / Sunday.
6. It's Thursday / Friday.
7. It's Wednesday / Monday.

3.  Listen, write and say

Sunday, Monday, Tuesday, Wednesday

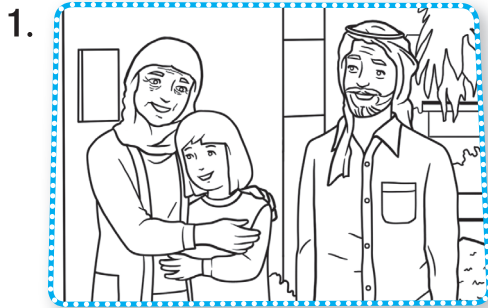

Monday

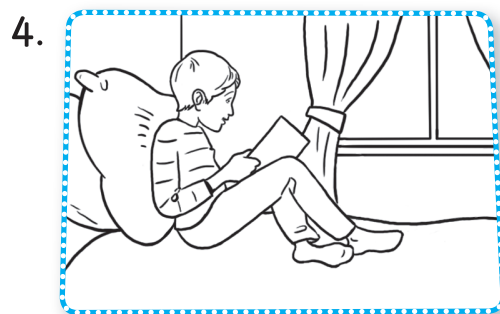
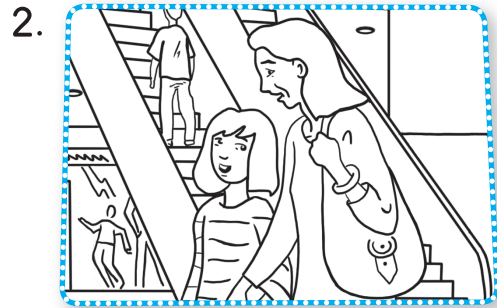

4.  Trace, listen and write

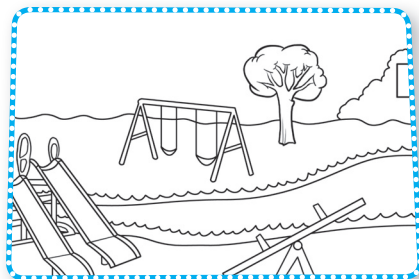
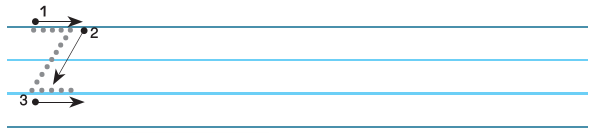
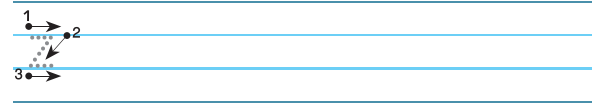

park

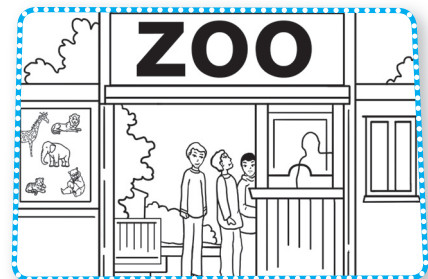

zoo

1. Look and complete

lives, Yes, Where

1.



Is it a park?

Yes, it is.

2.

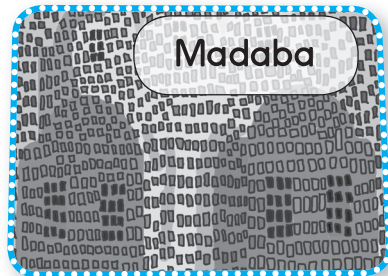

Where does Laila live?

She lives in
Madaba.

3.

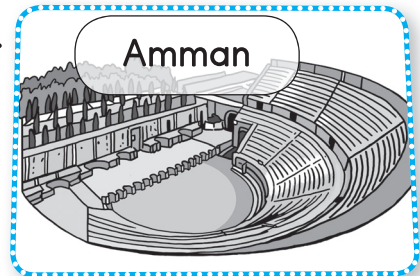
_____ does your
Grandpa live?

He lives in Amman.

2. Look, circle and say

Thursday	Friday	Saturday

- On Thursday, I help my grandmother. ✓ X
- On Friday, I go to the shops with my mum. ✓ X
- On Saturday, I visit my uncle, aunt and cousin. ✓ X

1. Look and circle

1.

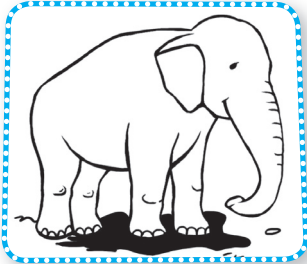

I can see a tiger. ✓ X

2.

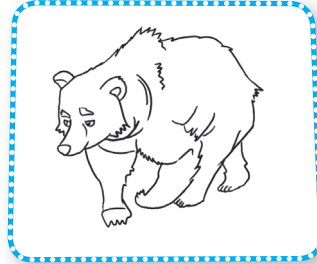

I can see a bear. ✓ X

2. Match, trace and copy

A

T

Y

t

y

a

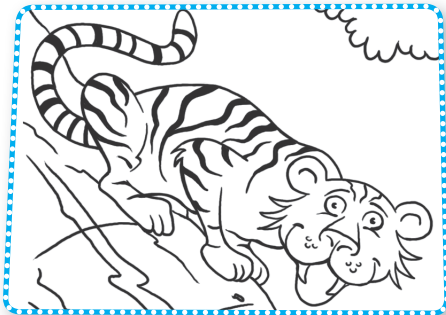

animals, tiger



1. It's a tiger .

2. They're .

3.  Listen and number

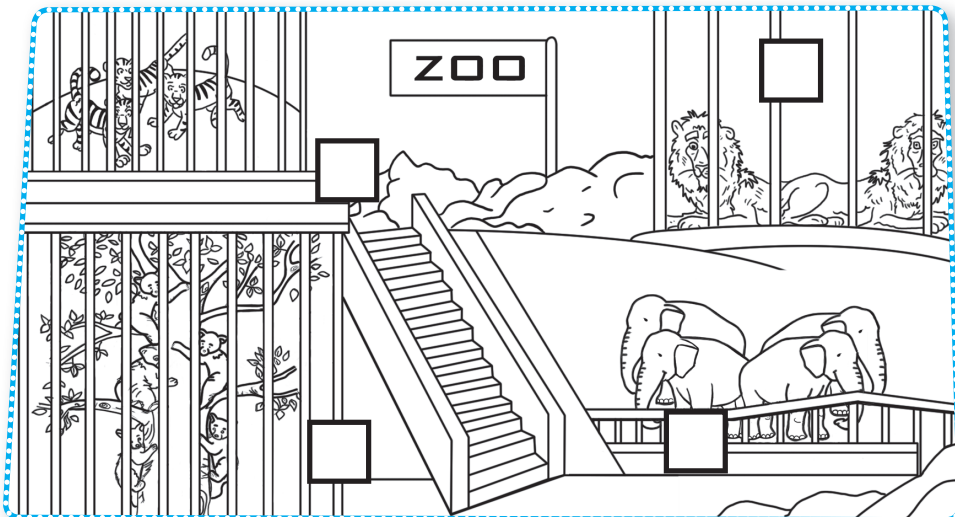

4. Write and match

big, old, small, young

1. It's big.

2. They're y.

3. They're o.

4. It's s.

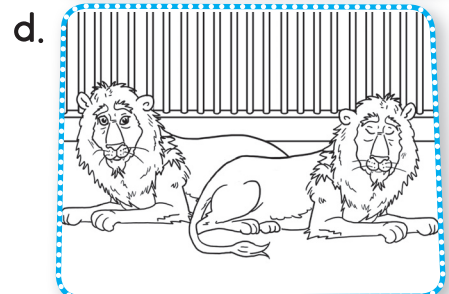
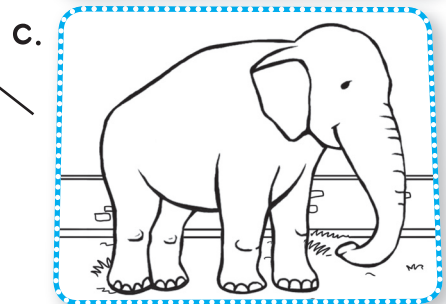
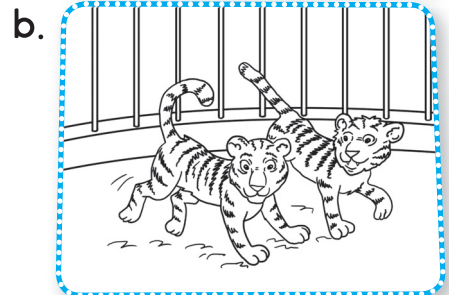
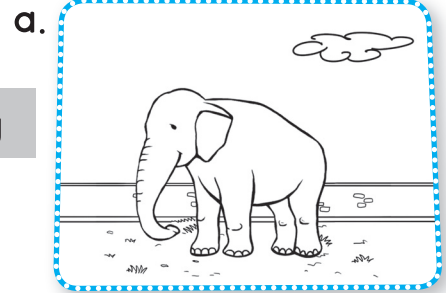

5. Listen, count and write

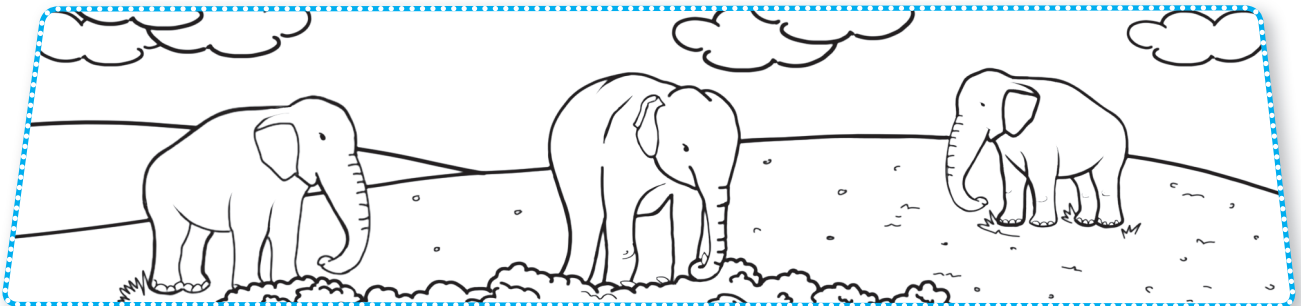

1. I can see _____.

2. They're _____.

1. Look and write

walk, swim, fly, sing

1.

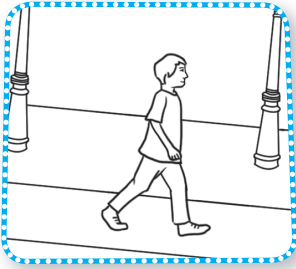

walk

2.

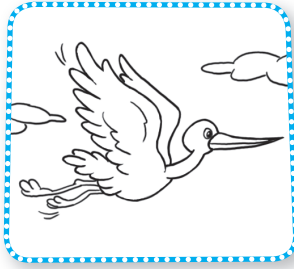

3.

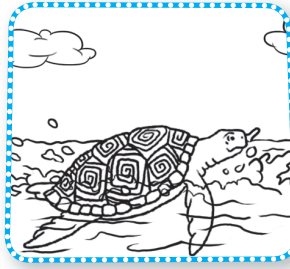

4.



2. Look, circle and say

1.

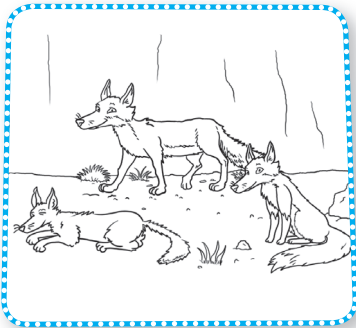

Can they sing?

Yes, they can. / No, they can't.

2.

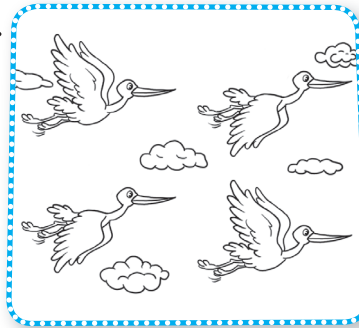

Can they fly?

Yes, they can. / No, they can't.

3.

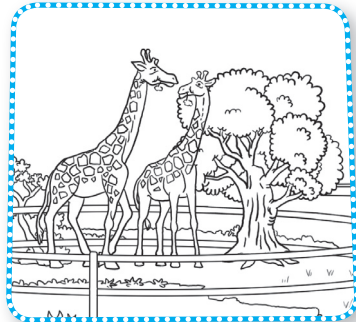

Can they climb?

Yes, they can. / No, they can't.

4.

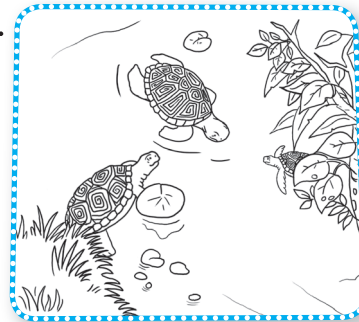

Can they swim?

Yes, they can. / No, they can't.

3.  Trace, listen and write

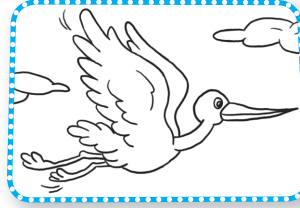
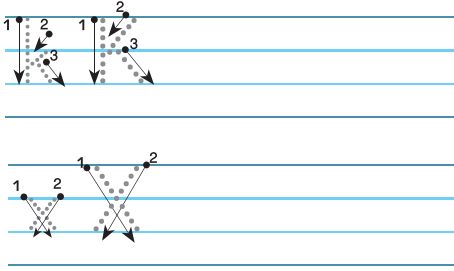

stork



fox

4.  Listen, ask and answer

Yes, they can. No, they can't.

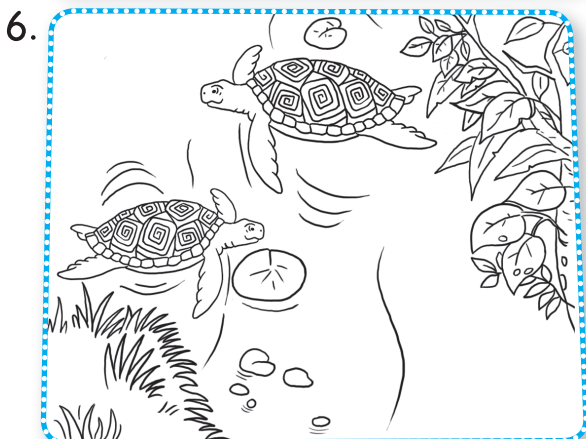
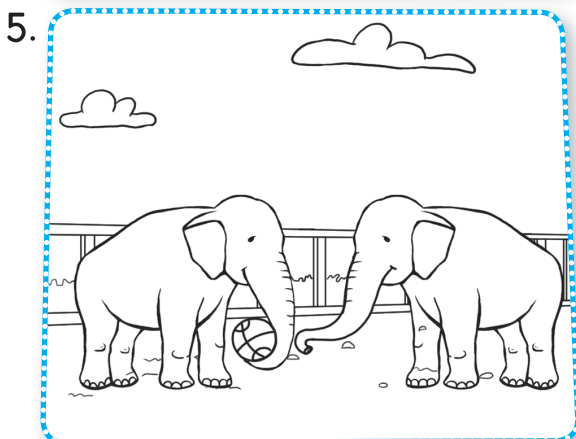
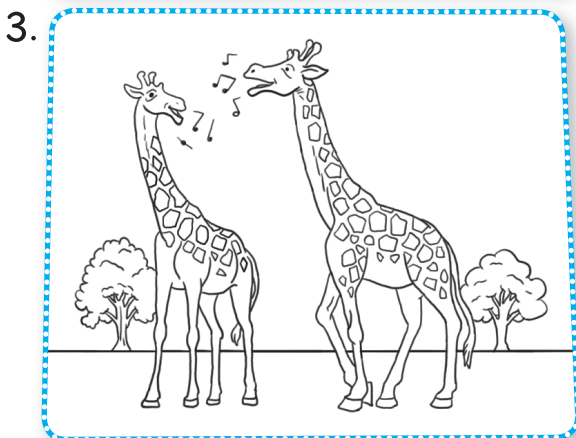
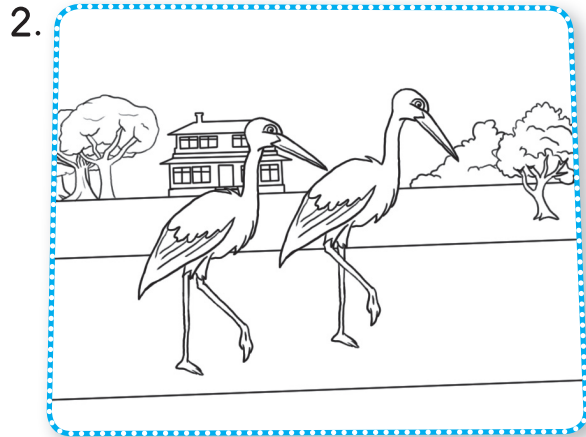
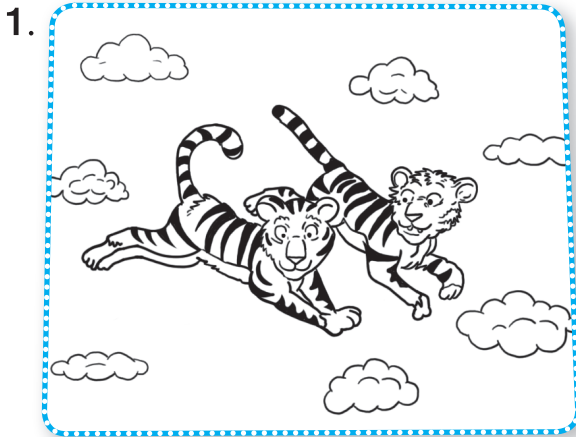

1. Look and write

1.



e a d h h e c a

headache

2.



t s m a h o c c h e a

stomachache

3.



e r a a e c h

earache

4.



o o a c h t t h e

toothache

2. Trace and write

1.



2.
1 ↓

He's

_____.

2 →
1 ↓
3 →

2.



1 ↓ 2 →

headache

She's got a _____.

2 ↓ 3 → 2 ↓

3. Match and write

I'm thirsty. I'm hungry. I'm ill. I'm tired.

1.

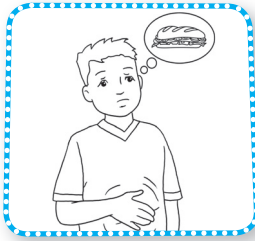

I'm hungry

2.

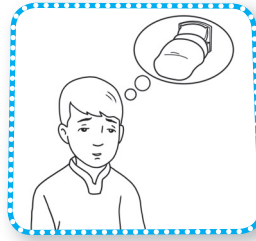

3.

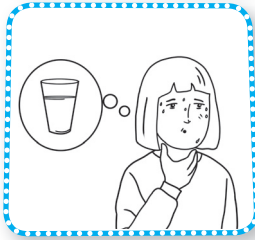

4.

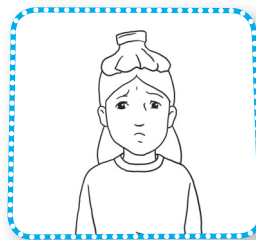

4. Look and circle

1.

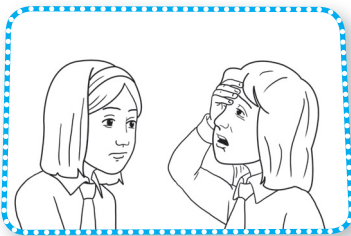

Girl 1: Have you got a headache?

Girl 2: Yes, I have. / No, I haven't.

2.

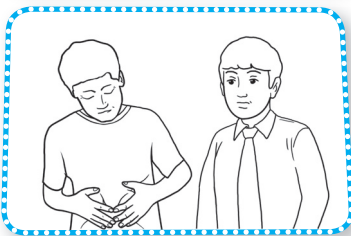

Boy 1: Have you got a toothache?

Boy 2: Yes, I have. / No, I haven't.

3.

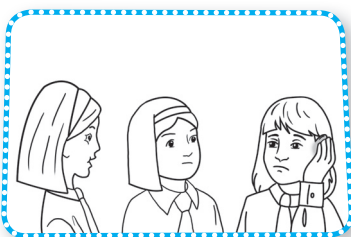

Girl 1: Has she got an earache?

Girl 2: Yes, she has. / No, she hasn't.

4.

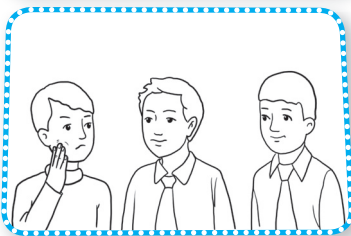

Boy 1: Has he got a stomachache?

Boy 2: Yes, he has. / No, he hasn't.

1.  Listen and write

1. It's a _____.

2. _____.

2. Match and write

old, small, young, big

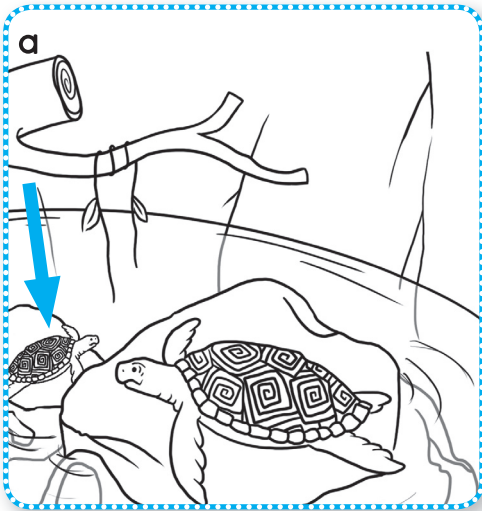

1. _____

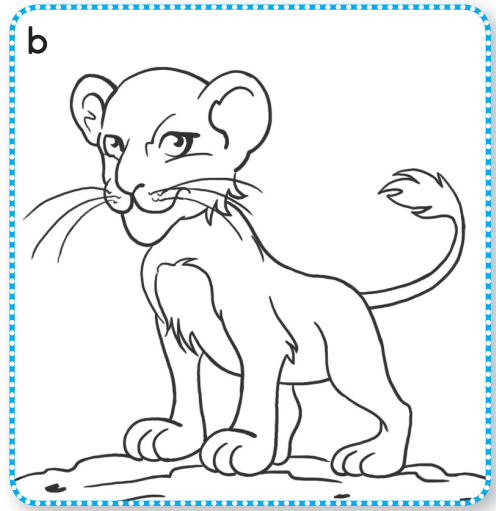

2. _____

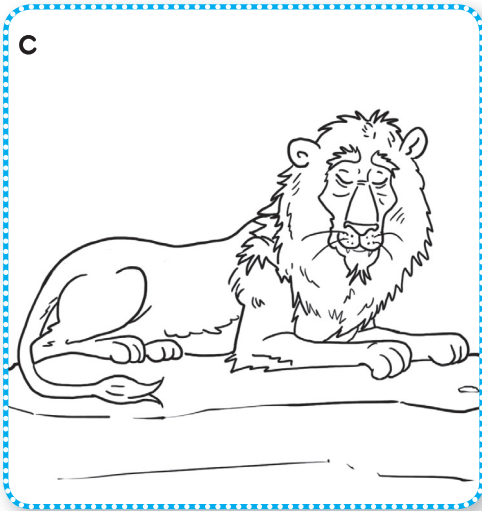

3. _____

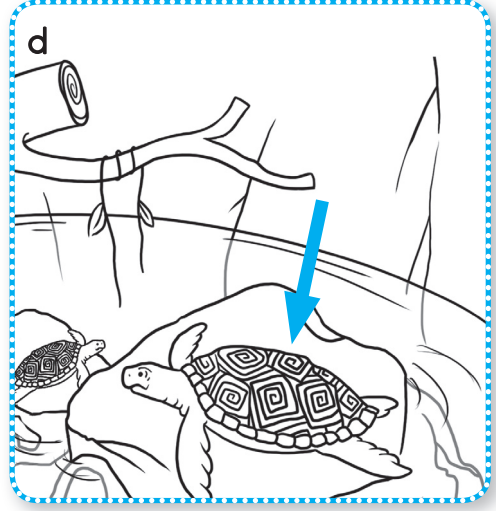

4. _____

1. Read, write and match

twenty-one	_____	16
twenty	_____	18
nineteen	_____	13
eighteen	_____	20
seventeen	_____	21
sixteen	_____	14
fifteen	_____	11
fourteen	_____	17
thirteen	_____	12
twelve	_____	15
eleven	_____	19

2. Look and complete

many, There are

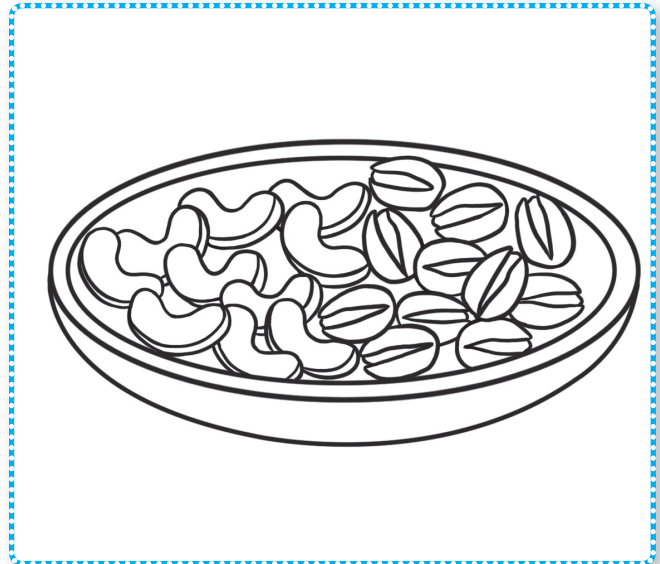
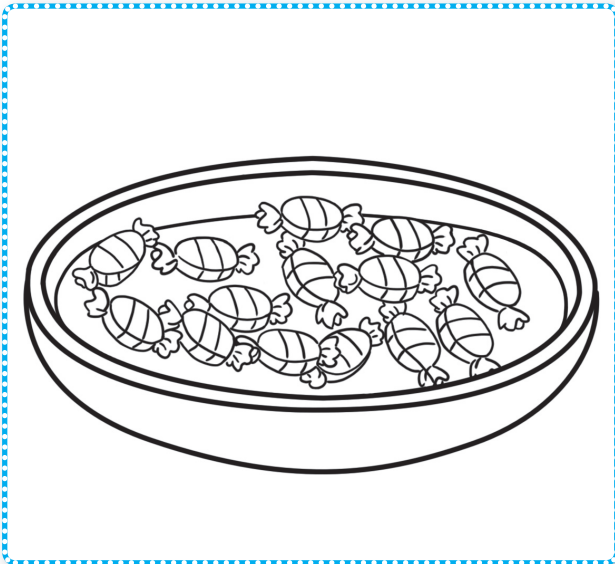

1. How _____ sweets
are there? There are fourteen.

2. How many nuts are there?
_____ twenty-one.

3. Trace and write

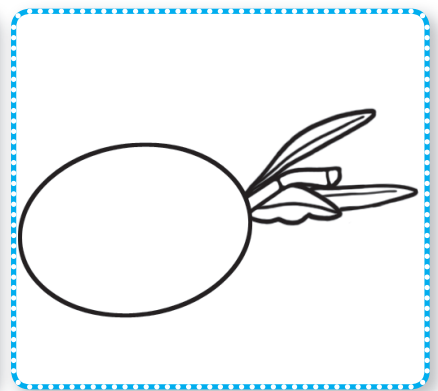
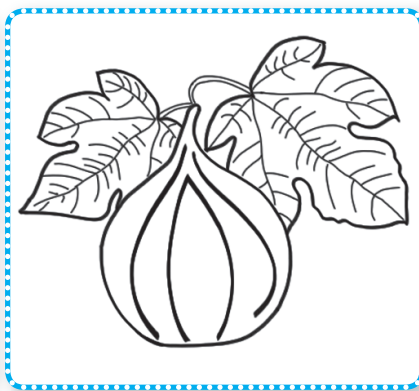
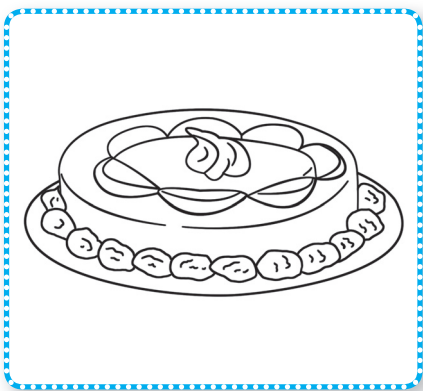

1. It's a cake.

2. It's a fig.

3. It's an olive.

4. Match, listen and check

1. Can I have
2. How many
3. Twenty,
4. Here
5. Thank

would you like?
please.
you.
some cakes, please?
you are.

1. Read and draw

1.

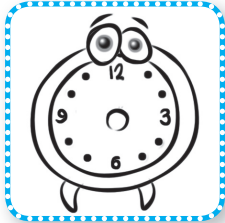

It's half past two.

2.

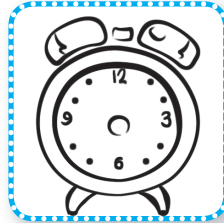

It's six o'clock.

3.

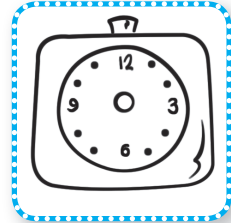

It's eleven o'clock.

2. Match and write

go to bed, go to school, get up,
brush teeth, have breakfast, have lunch

1.



get up

2.

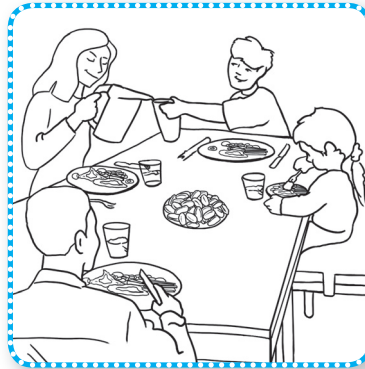

3.

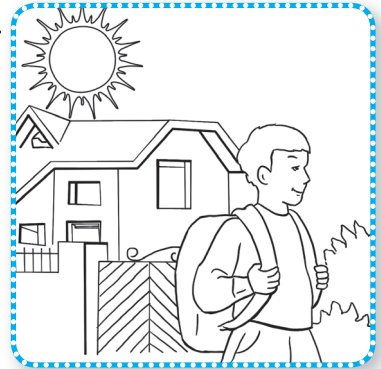

4.

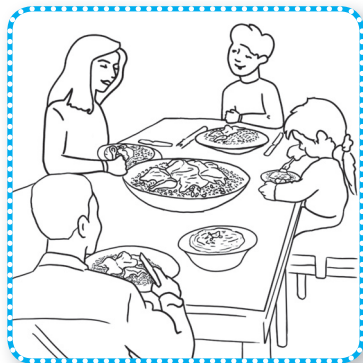

5.

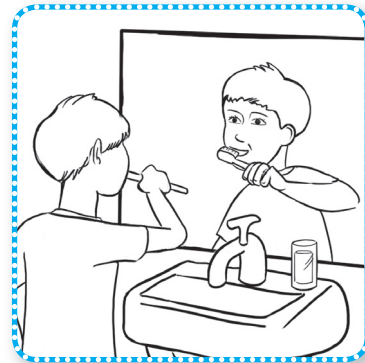

6.

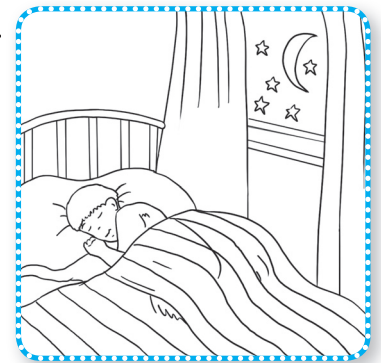

3. Listen and match

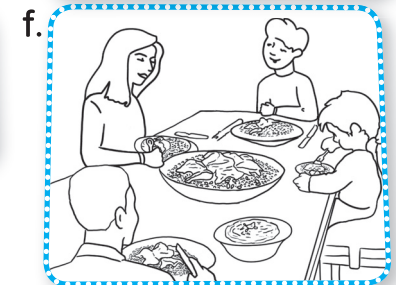
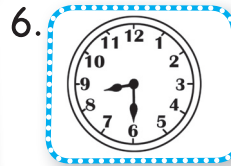
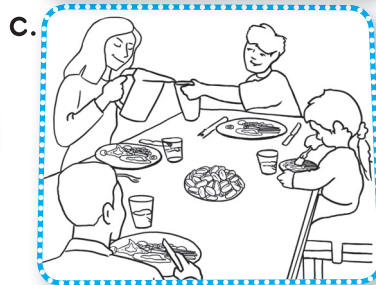
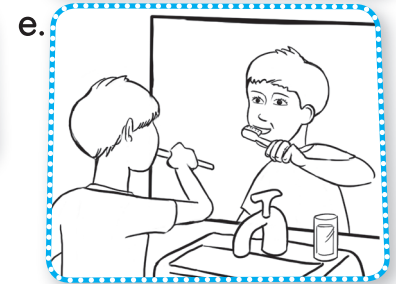
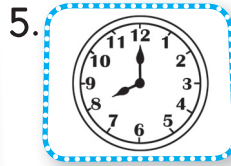
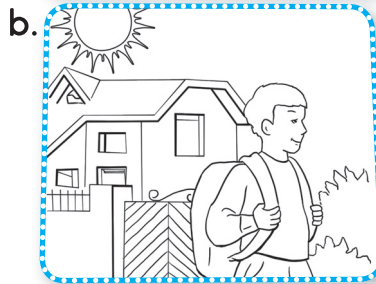
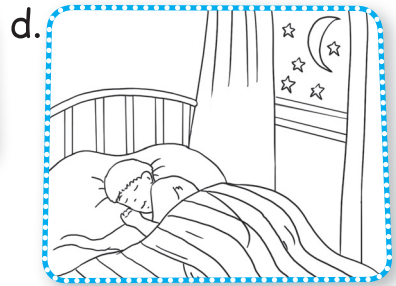
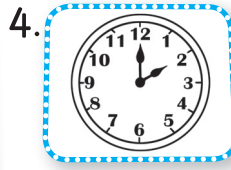
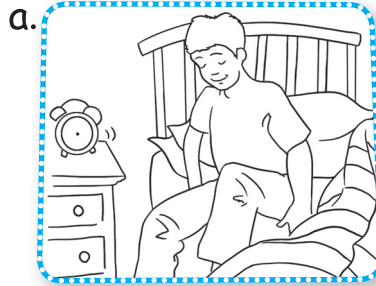
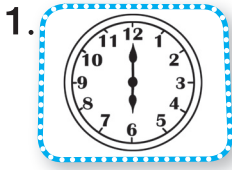

4. Trace, listen and write

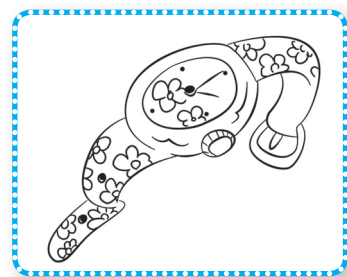
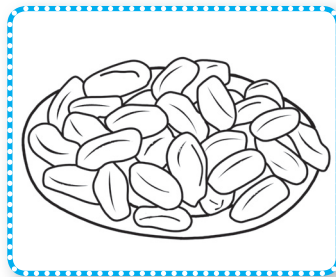
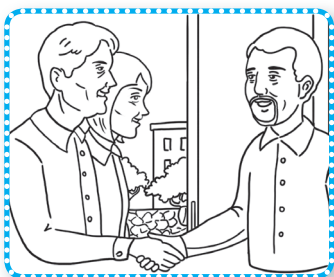
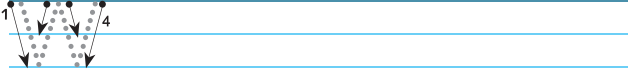
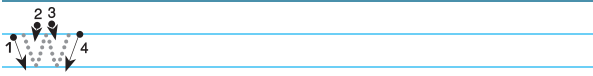

visitor | dates | watch

1.  Listen and colour

1.

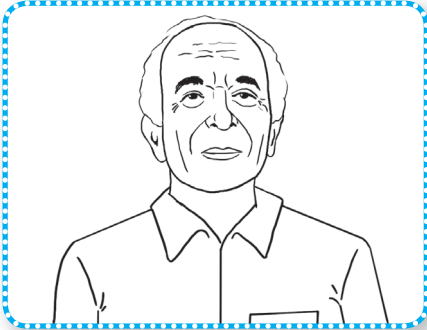

2.

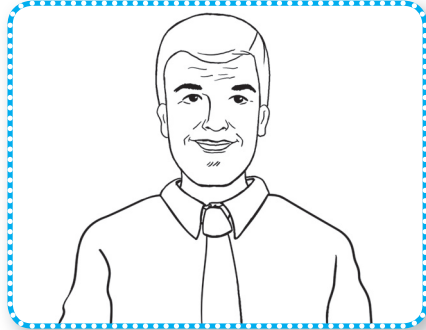

3.

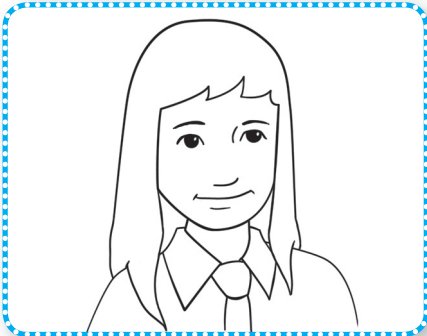

4.

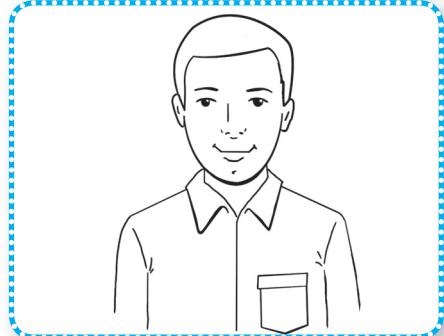

2. Trace and write

1.

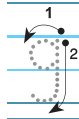
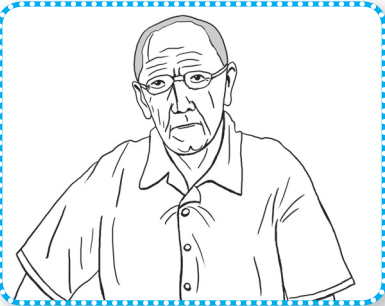

grey

He's got _____ hair.

2.

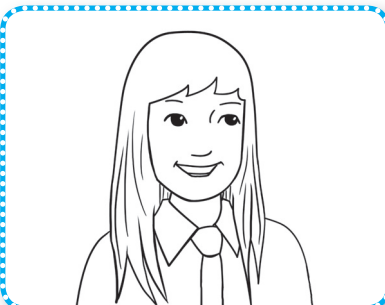

long

She's got _____ hair.

3. Look and circle

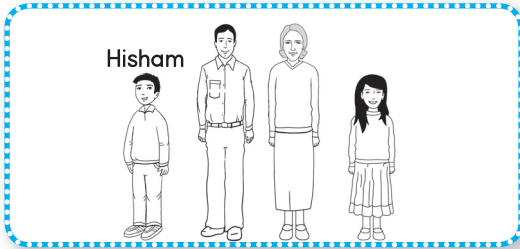

1. Hisham is short. X
2. He has got short brown hair. X

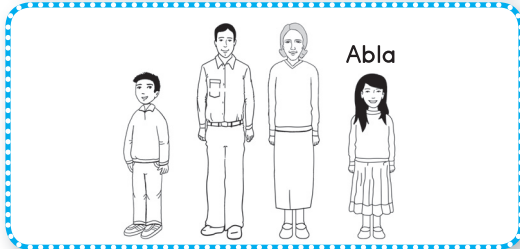

3. Abla is tall. X
4. She has got long black hair. X

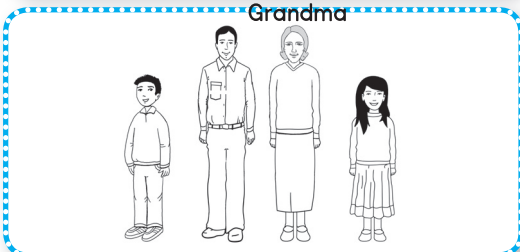

5. Grandma is tall. X
6. She has got short black hair. X

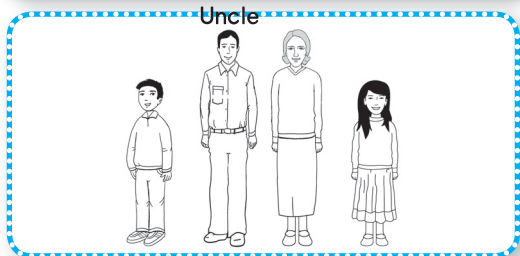

7. My uncle is short. X
8. He has got short grey hair. X

4. Write, listen and check

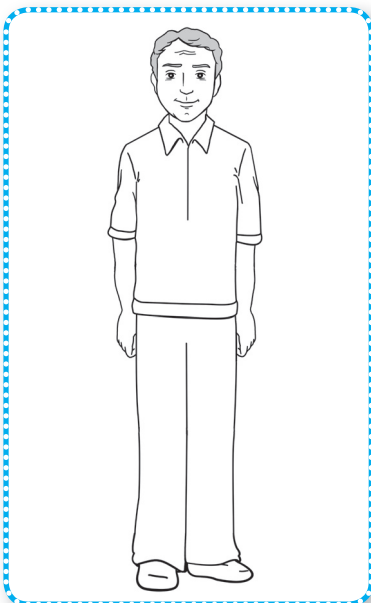

black, grey, got, tall

He's tall.

He's _____ short _____

hair and _____ eyes.

1. Look, count and write

one, nineteen, twenty-one, sixteen

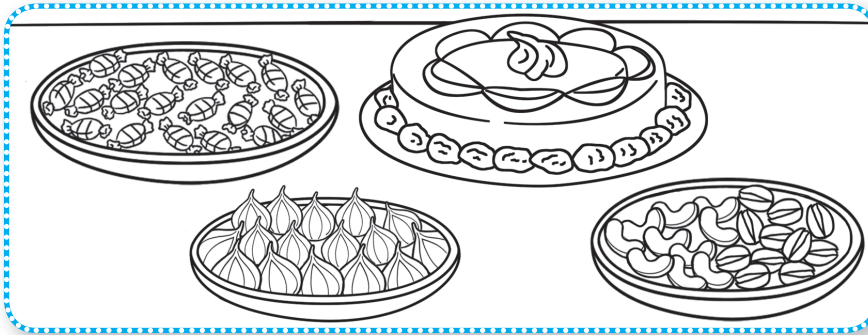

1. How many nuts are there?

There are twenty-one.

3. How many figs are there?

There are _____.

2. How many sweets are there?

There are _____.

4. How many cakes are there?

There's _____.

2. Look and circle

1.

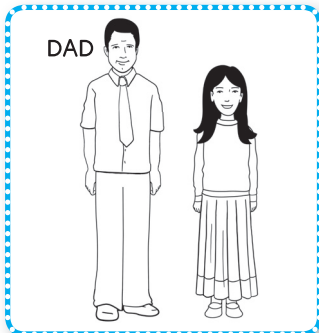

My dad's tall / short.

He's got short / long black hair.

2.

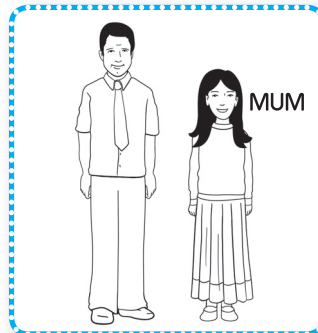

My mum's tall / short.

She's got long black / brown hair.

3.

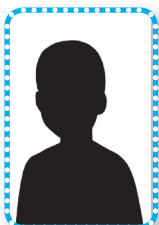

I'm tall / short.

I've got short / long black / brown / hair and black / brown / grey / blue / green eyes.

1.  Say, write and listen

1.

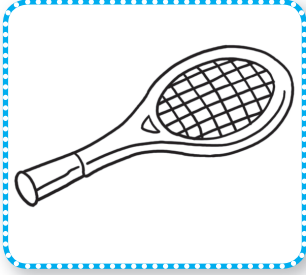

a tennis racquet

2.

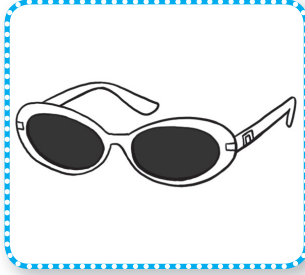

3.



4.



5.

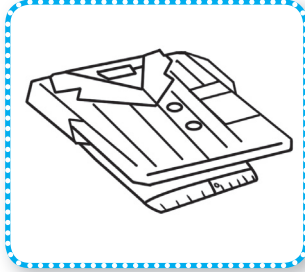

6.



2. Look and circle

1.

This is a / These are sunglasses.

2.



This is a / These are football.

3.







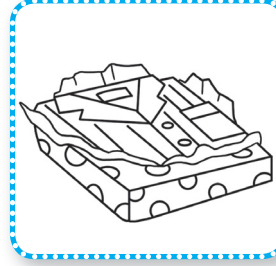

This is a / These are T-shirt.

4.

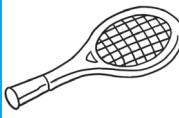

This is a / These are pyjamas.

3.  Listen and tick

						
	✓					
						



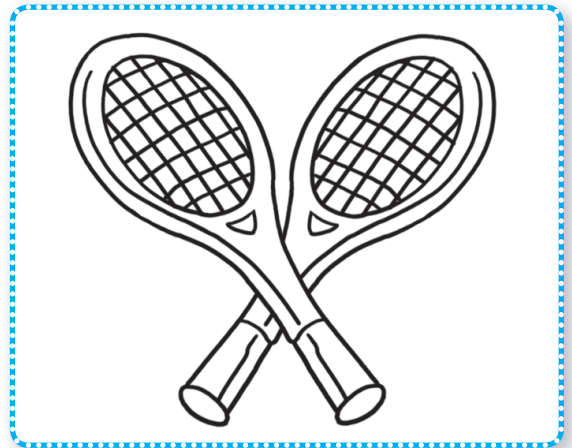
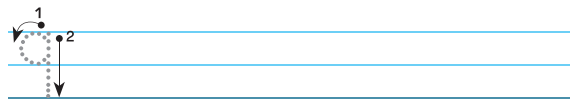

4. Trace and write



1. This is a notebook.

2. These are tennis rackets.

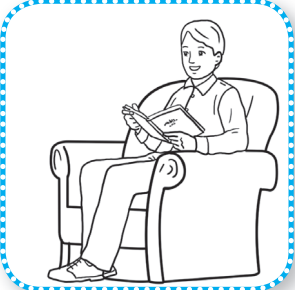
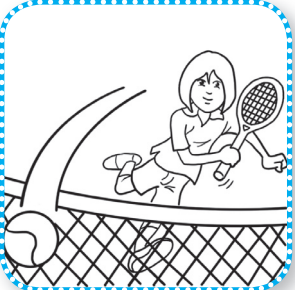
1. Match and write

- a.  1. reading
- b.  2. cycling
- c.  3. playing tennis
- d.  4. running
- e.  5. playing football
- f.  6. painting

2. Trace and write

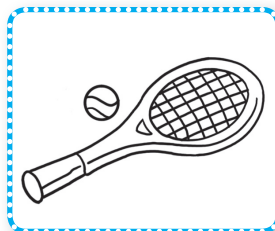

1. Do you like salad ?

2. Do you like playing tennis ?

3. Look, ask, answer and circle

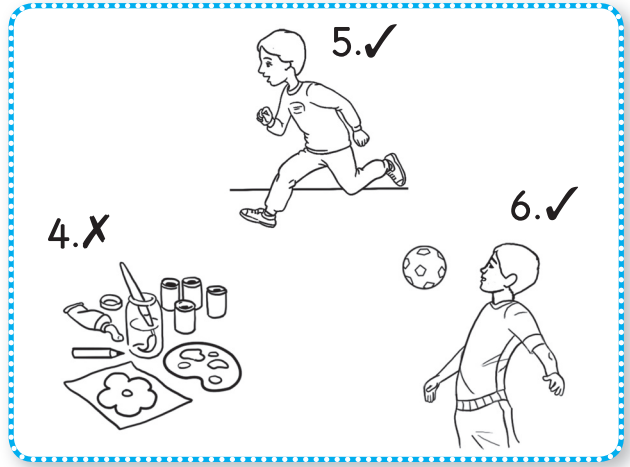
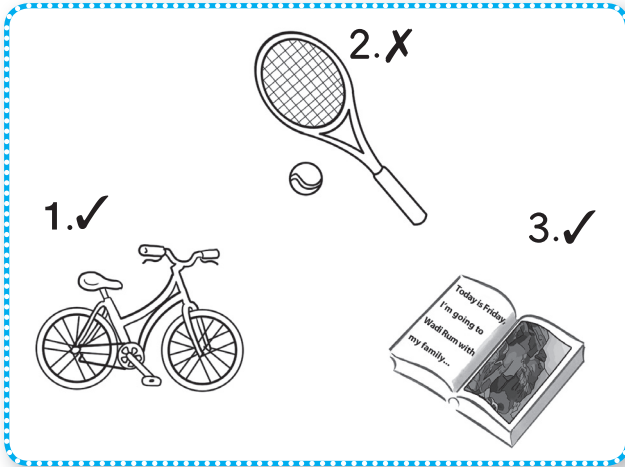

1. Yes, I do / No, I don't.
2. Yes, I do. / No, I don't.
3. Yes, I do. / No, I don't.
4. Yes, I do. / No, I don't.
5. Yes, I do. / No, I don't.
6. Yes, I do. / No, I don't.

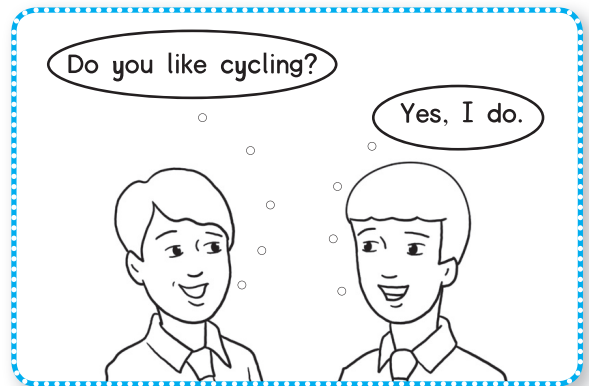

4. Listen and tick ✓ or cross X

	✓			

1.  Match, listen and say

A
C
E
G
I
K
M
O
Q
S
U
W
Y

u
c
e
g
i
o
w
y
s
a
k
m
q

B
D
F
H
J
L
N
P
R
T
V
X
Z

d
z
x
p
r
t
b
v
l
f
h
j
n

2.  Listen and write

1.

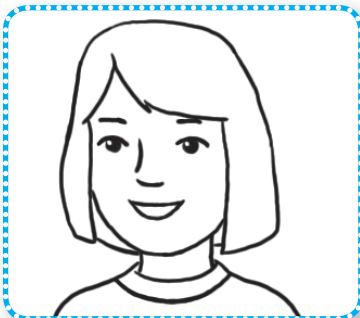

Mariam

Salameh

2.

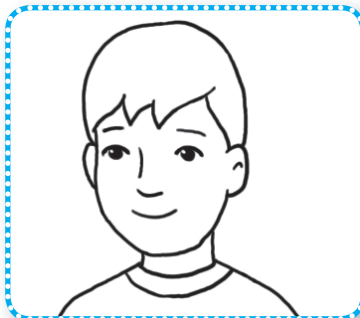

Ibrahim

3.



Nadia

3.  Listen, circle and point

b o c a k e y f k h a t I c v a x football p w e j n o t e b o o k c b

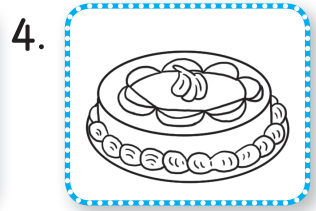
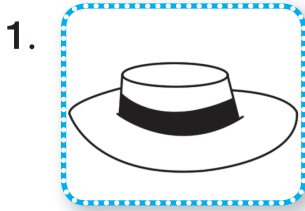

4. Look, answer and write



What's his surname?

It's _____.

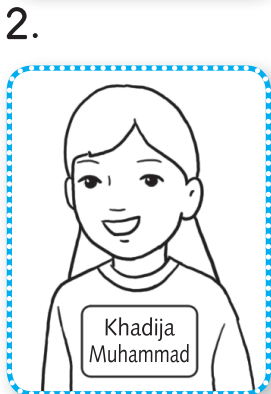

What's her surname?

It's _____.

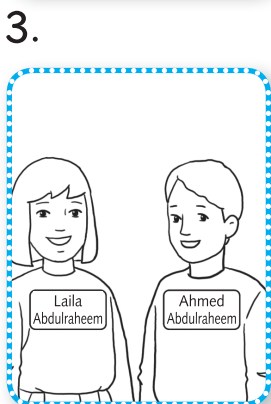

What's their surname?

It's _____.

1. Look, circle and say

1.

This is / These
are for her.

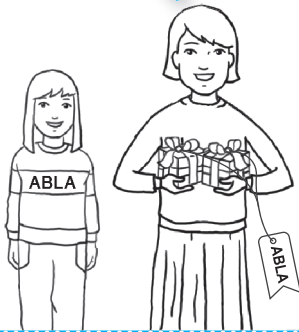







2.

This is for you / me
/ him / her / them.

2.  Look, write and listen

football, Do, like, No, painting, don't, do

	😊	☹️
 ISSA		
 LAILA		

1. Laila: Do you like cycling, Issa?

Issa: No, I . I like .

2. Issa: you like reading, Laila?

Laila: Yes, I .

3. Issa: Do you like playing , Laila?

Laila: , I don't.

Wordlist

alphabet (U:15)
alright (U:7)
animal (U:5)
aunt (U:2 & U:4)
baby (U:2)
bear (U:5 & U:8)
big (U:5 & U:8)
board (U:1 & U:4)
breakfast (U:12)
brown (U:11 & U:12)
brush teeth (U:10)
cake (U:9 & U:12)
catch (U:6 & U:8)
children (U:1)
climb (U:6 & U:8)
cooking (U:14 & U:16)
cousin (U:2 & U:4)
cycling (U:14 & U:16)
days of the week (U:3 & U:4)
desk (U:1 & U:4)
earache (U:7 & U:8)
elephant (U:5 & U:8)
Excuse me (U:7)
fig (U:9 & U:12)
fly (U:6 & U:8)
football (U:13 & U:16)
fox (U:6)
get up (U:10 & U:12)
giraffe (U:6 & U:8)
go to bed (U:10 & U:12)
go to school (U:10 & U:12)
good morning (U:1 & U:4)
grandma (U:2 & U:4)
grandpa (U:2 & U:4)
grandparent (U:2)
grey (U:11 & U:12)
guess (U:6 & U:8)
half past (U:10 & U:12)
hat (U:13 & U:16)
have breakfast (U:10)
have lunch (U:10)
headache (U:7 & U:8)
help (U:3 & U:4)
home (U:7)
hungry (U:7 & U:8)
ill (U:7 & U:8)
Jordan (U:1 & U:4)
letter (U:15 & U:16)
lion (U:5 & U:8)
live (v) (U:2 & U:4)
long (U:11)
lunch (U:12)
notebook (U:13)
numbers 11-21 (U:9)
nut (U:9 & U:12)
o'clock (U:10 & U:12)
olive (U:9 & U:12)
page (U:1)
painting (U:14 & U:16)
pencil case (U:1 & U:4)
play (U:3 & U:4)
playing football (U:4 & U:14)
playing tennis (U:16)
present (U:13)
pyjamas (U:13 & U:16)
read (U:3 & U:4)
reading (U:14 & U:16)
right (U:15)
rubber (U:1 & U:4)
ruler (U:1 & U:4)
running (U:14 & U:16)
(school) trip (U:3)
see (U:5)
short (U:11 & U:12)
sing (U:6 & U:8)
small (U:5 & U:8)
spell (U:15 & U:16)
stomachache (U:7 & U:8)
stork (U:6 & U:8)
sunglasses (U:13 & U:16)
surname (U:15 & U:16)
sweet (U:9 & U:12)
tall (U:11 & U:12)
tennis (U:14)
tennis racquet (U:13 & U:16)
thirsty (U:7 & U:8)
tidy bedroom (U:3)
tiger (U:5)
time (U:10)
tired (U:7)
today (U:3)
toothache (U:7 & U:8)
T-shirt (U:13 & U:16)
turn (U:1)
turtle (U:6 & U:8)
uncle (U:2 & U:4)
visit (U:3 & U:4)
visitor (U:10 & U:12)
walk (U:6 & U:8)
watch (U:10)
who (U:2)
wrong (U:15)
young (U:5 & U:8)
zoo (U:3 & U:4)