

Electrical Circuit (1)

Superposition (week7 class2)

Dr. Akram Al-Mahrouk

Philadelphia University

Chapter 4 Circuit Theorems 127

- 4.1 Introduction 128
- 4.2 Linearity Property 128
- 4.3 Superposition 130
- 4.4 Source Transformation 135
- 4.5 Thevenin's Theorem 139
- 4.6 Norton's Theorem 145
- 4.7 †Derivations of Thevenin's
and Norton's Theorems 149
- 4.8 Maximum Power Transfer 150
- 4.9 Verifying Circuit Theorems
with *PSpice* 152
- 4.10 †Applications 155
 - 4.10.1 Source Modeling
 - 4.10.2 Resistance Measurement
- 4.11 Summary 160
 - Review Questions 161
 - Problems 162
 - Comprehensive Problems 173

Superposition



Steps to Apply Superposition Principle:

1. Turn off all independent sources except one source. Find the output (voltage or current) due to that active source using the techniques covered in Chapters 2 and 3.
2. Repeat step 1 for each of the other independent sources.
3. Find the total contribution by adding algebraically all the contributions due to the independent sources.

Superposition

Find V using

1. voltage source only?
2. Current source only?
3. Both sources?

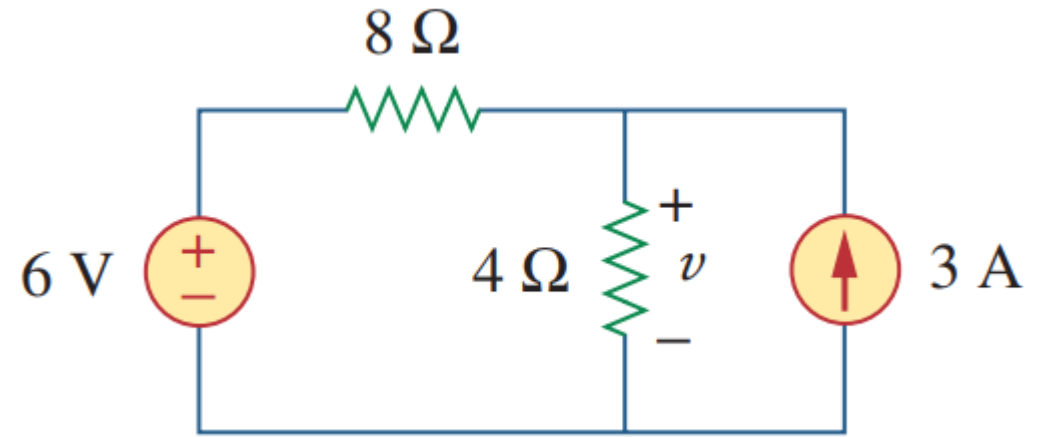

Superposition

Find V using

1. voltage source only?
2. Current source only?
3. Both sources?

@ $v_{@v=6}$

$$v_{v=6} = 6 \frac{4}{4+8} = 2V$$

@ $v_{@i=3}$

$$i_{@4\Omega} = 3 \frac{8}{4+8} = 2A$$

$$v_{@i=3} = 2 * 4 = 8V$$

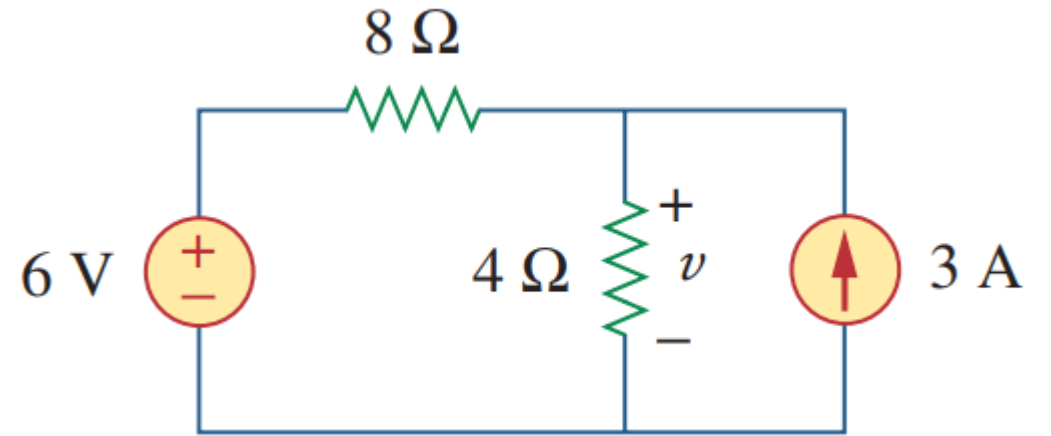

Final v

$$v = 2 + 8 = 10V$$

Superposition

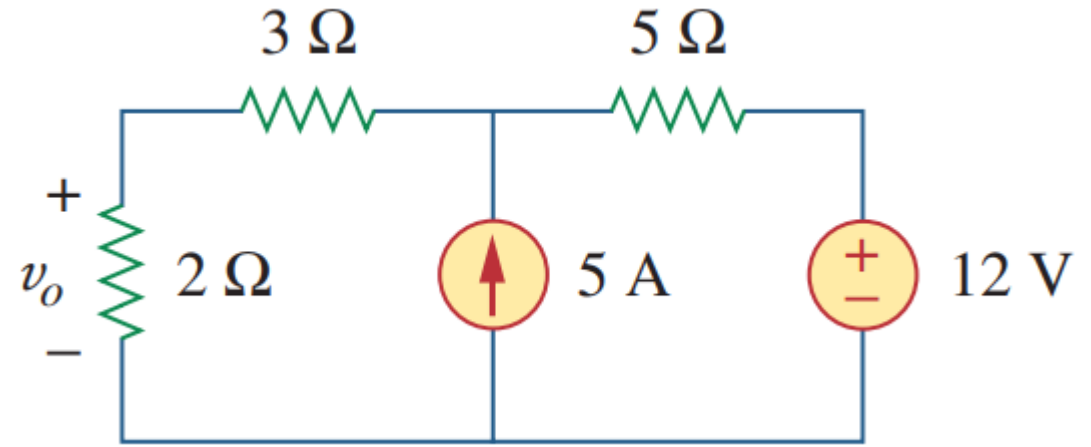

Superposition

Find v_o using

1. voltage source only?
2. Current source only?
3. Both sources?

@ $v@v=12$

$$v_{v=6} = 12 \frac{2}{2 + 3 + 5} = 2.4V$$

@ $v@i=5$

$$i_{@2\Omega} = 5 \frac{5}{5 + 5} = 2.5A$$

$$v_{@i=5} = 2.5 * 2 = 5V$$

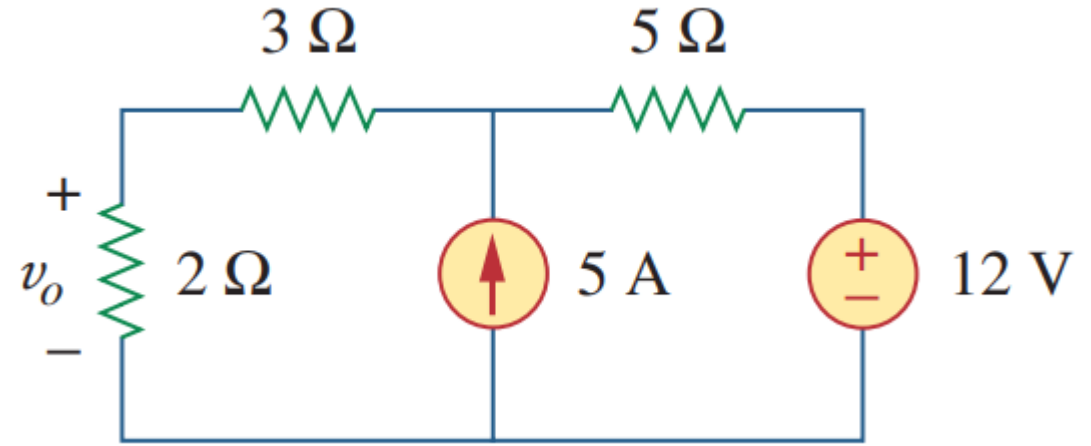

Final v

$$v = 2.4 + 5 = 7.4V$$

Superposition

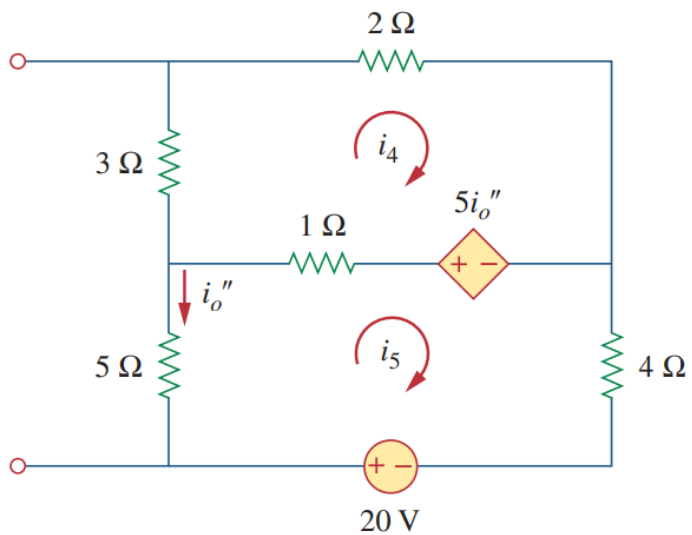
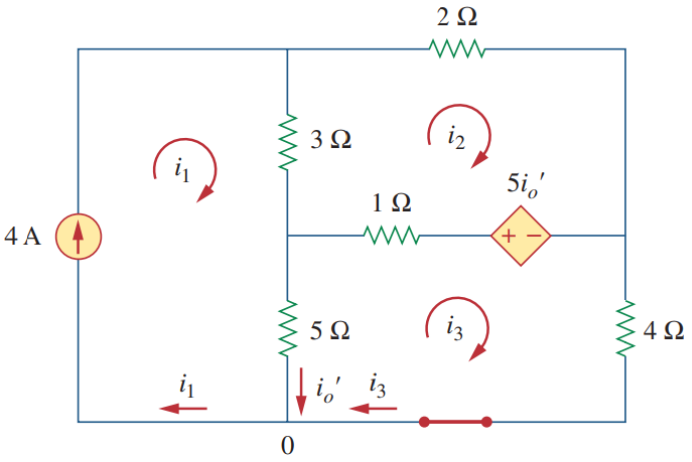
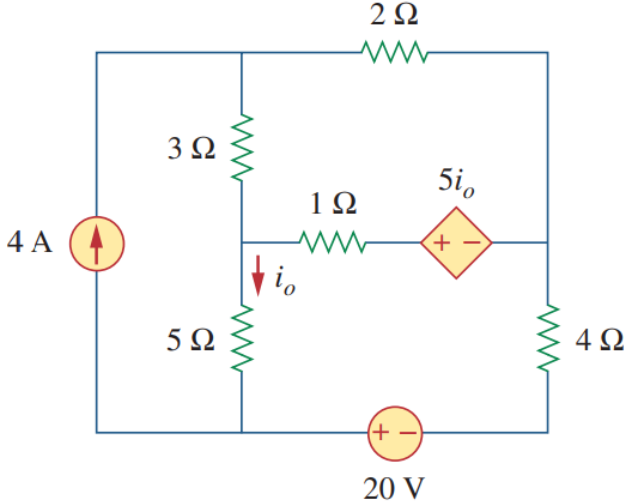

Superposition

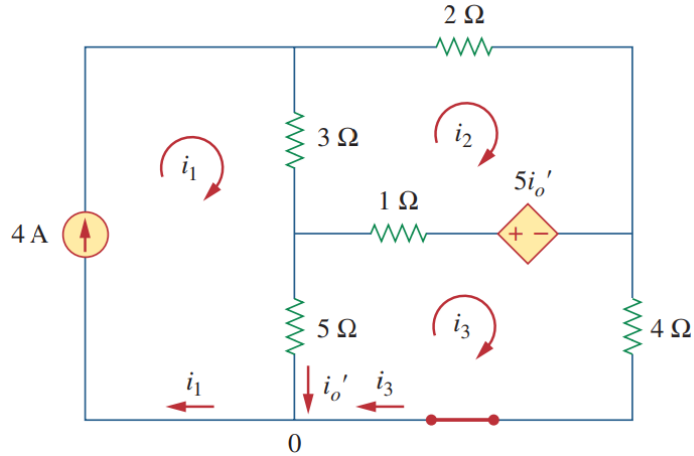

@ i'_o @4A

$$i_1 = 4 \text{ A} \quad i'_o = i_1 - i_3$$

$$3(i_2 - i_1) + 2i_2 - 5(i_1 - i_3) + i_2 - i_3 = 0$$

$$5(i_3 - i_1) + i_3 - i_2 + 5(i_1 - i_3) + 4i_3 = 0$$

$$i_1 = 4 \text{ A}, \quad i_2 = 4.706 \text{ A}, \quad i_3 = 0.941 \text{ A}$$

$$i'_o = 3.059 \text{ A}$$

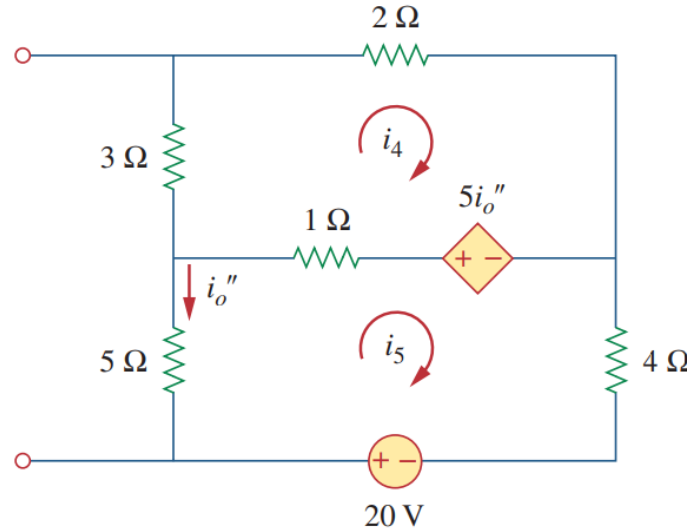

@ i''_o @20V

$$3i_4 + 2i_4 - 5(-i_5) + i_4 - i_5 = 0$$

$$5(i_5) + i_5 - i_4 + 5(-i_5) + 4i_5 - 20 = 0$$

$$i_4 = -2.353 \text{ A}, \quad i_5 = 3.529 \text{ A}$$

$$i''_o = -3.529 \text{ A}$$

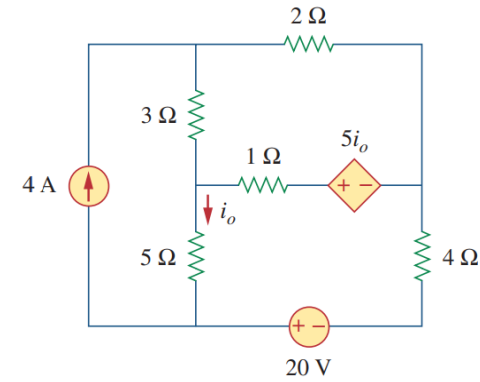

Final i_o

$$i_o = i'_o + i''_o$$

$$i_o = 3.059 - 3.529$$

$$i_o = -0.47 \text{ A}$$

