

Electrical Circuit (1)

Thevenin Theorem (Week9 Class1)

Dr. Akram Al-Mahrouk

Philadelphia University

Chapter 4 Circuit Theorems 127

- 4.1 Introduction 128
- 4.2 Linearity Property 128
- 4.3 Superposition 130
- 4.4 Source Transformation 135
- 4.5 Thevenin's Theorem 139
- 4.6 Norton's Theorem 145
- 4.7 †Derivations of Thevenin's
and Norton's Theorems 149
- 4.8 Maximum Power Transfer 150
- 4.9 Verifying Circuit Theorems
with *PSpice* 152
- 4.10 †Applications 155
 - 4.10.1 Source Modeling
 - 4.10.2 Resistance Measurement
- 4.11 Summary 160
 - Review Questions 161
 - Problems 162
 - Comprehensive Problems 173

Thevenin's Theorem

Thevenin's theorem states that a linear two-terminal circuit can be replaced by an equivalent circuit consisting of a voltage source V_{Th} in series with a resistor R_{Th} , where V_{Th} is the open-circuit voltage at the terminals and R_{Th} is the input or equivalent resistance at the terminals when the independent sources are turned off.

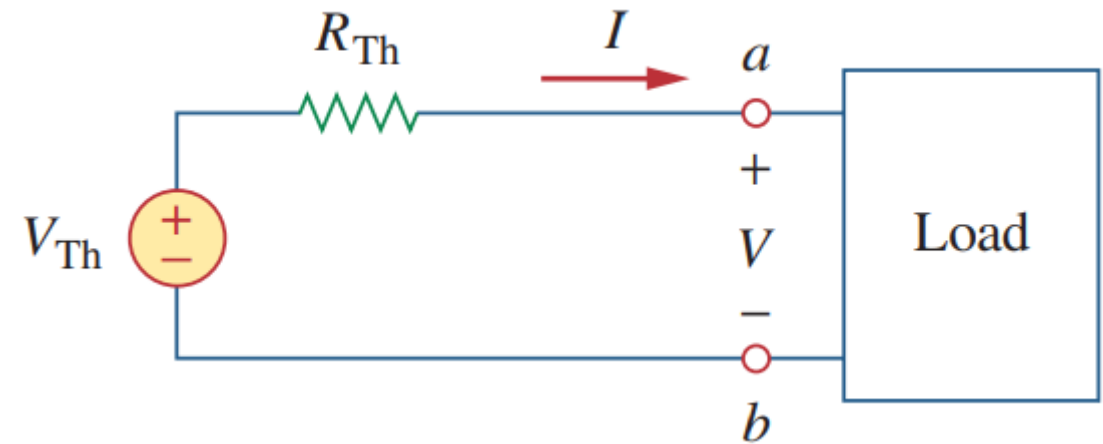
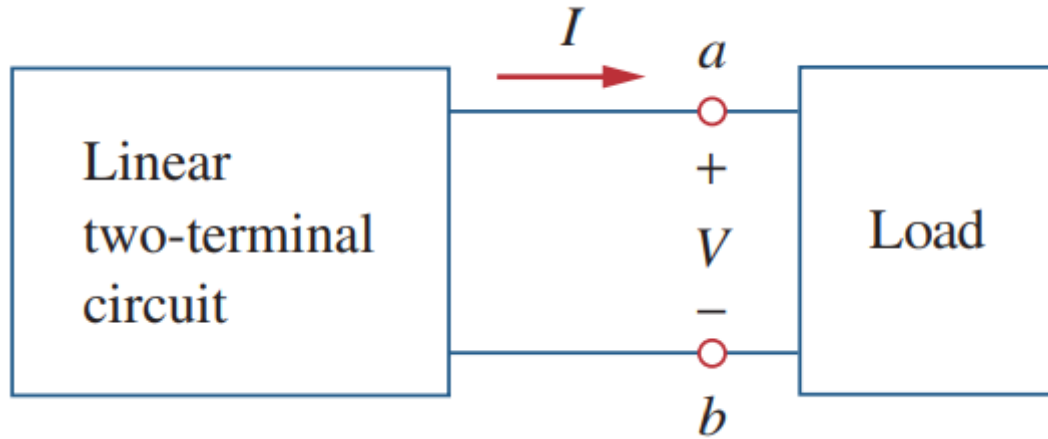

Thevenin's Theorem

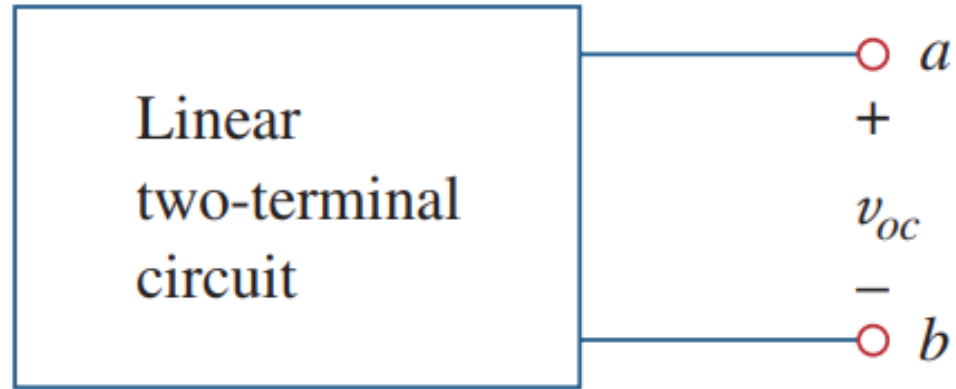

$$V_{\text{Th}} = v_{oc}$$

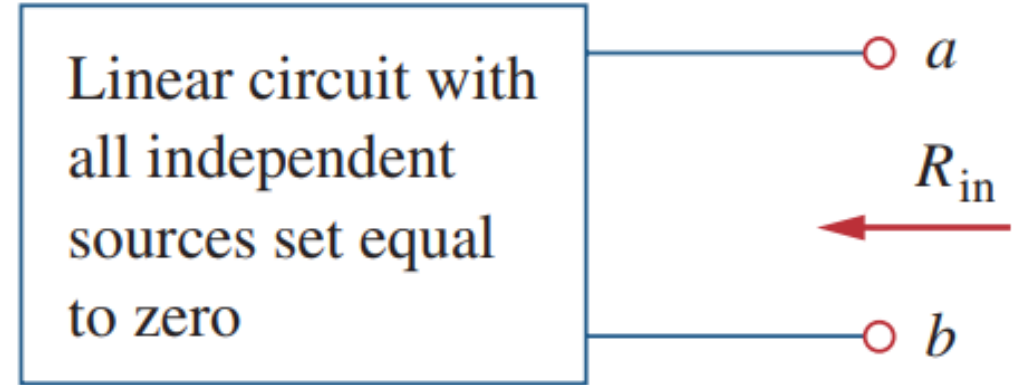

$$R_{\text{Th}} = R_{\text{in}}$$

Thevenin's Theorem

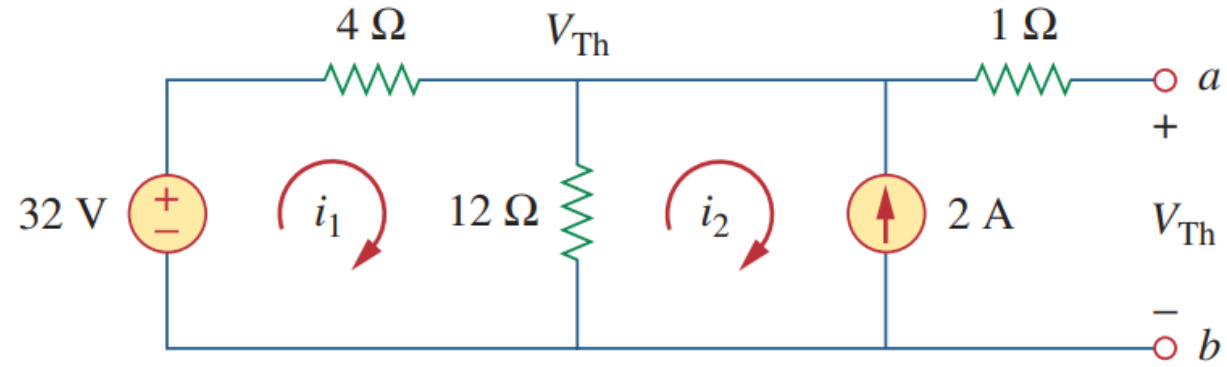
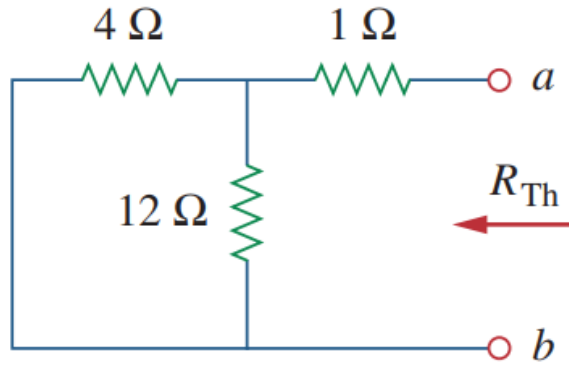
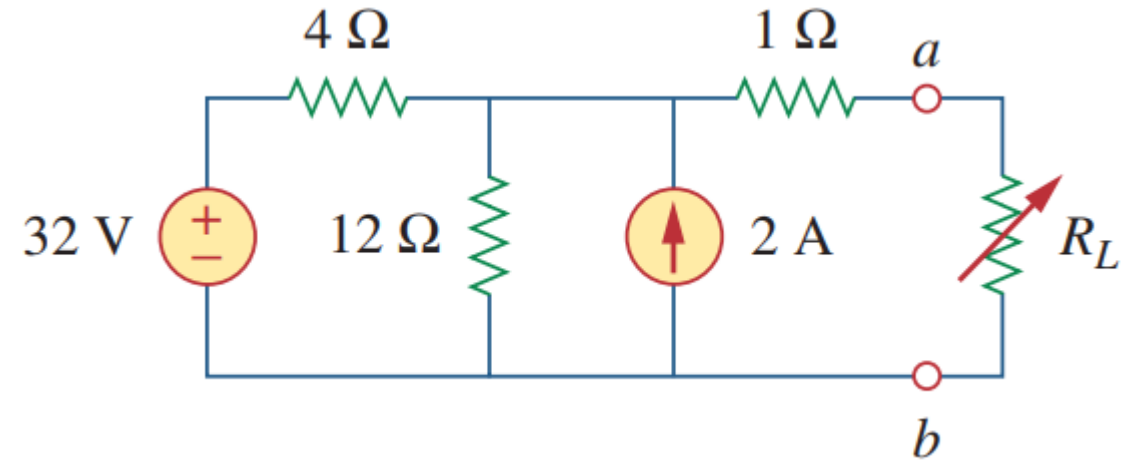

Thevenin's Theorem

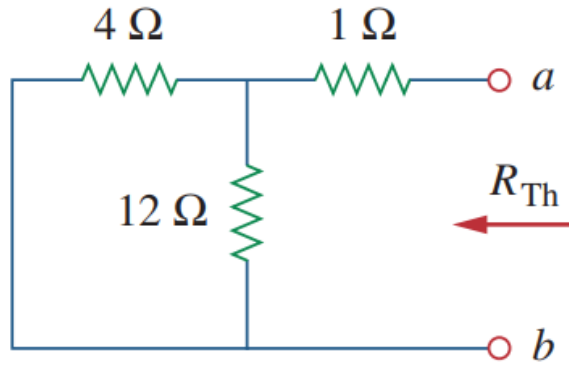
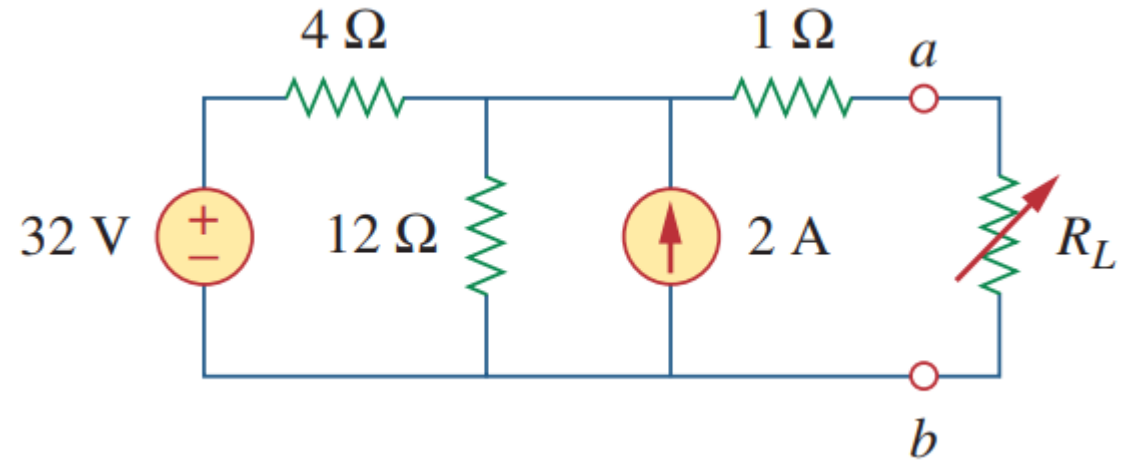

$$R_{th} = (4 \parallel 12) + 1 = 4 \Omega$$

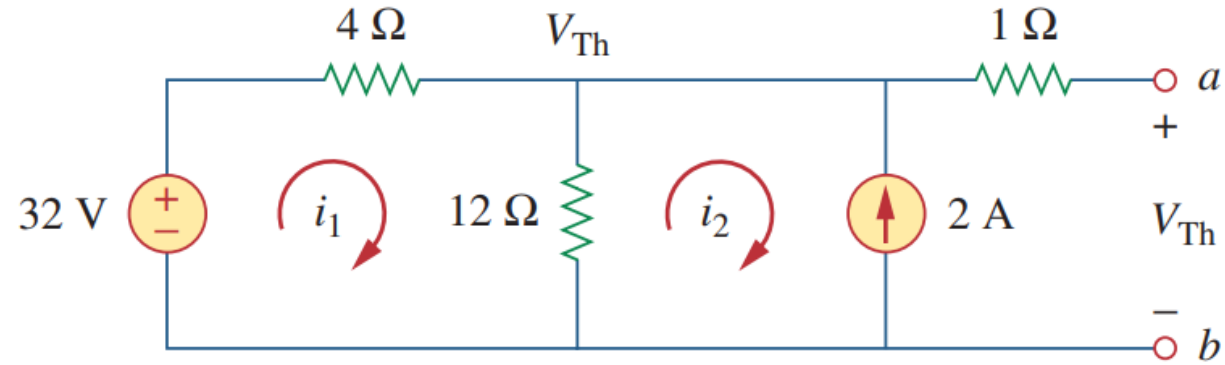

$$-32 + 4i_1 + 12i_1 - 12i_2 = 0$$

$$i_2 = -2A \quad i_1 = 0.5A$$

$$V_{th} = (0.5 - -2) * 12 = 30V$$

Thevenin's Theorem

Answer: $V_{Th} = 6\text{ V}$, $R_{Th} = 3\ \Omega$, $I = 1.5\text{ A}$.

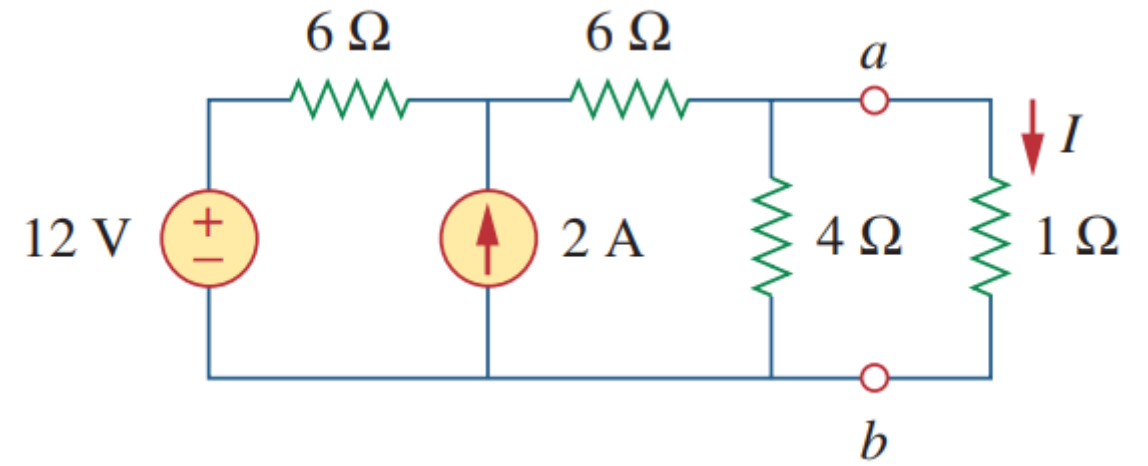

Thevenin's Theorem

Answer: $V_{Th} = 6\text{ V}$, $R_{Th} = 3\ \Omega$, $I = 1.5\text{ A}$.

$$R_{th} = (6 + 6) \parallel 4 = 3\ \Omega$$

$$-12 + 6i_1 + 6i_2 + 4i_2 = 0$$

$$i_2 - i_1 = 2$$

$$i_1 = -0.5\text{ A} \quad i_2 = 1.5\text{ A}$$

$$V_{th} = (1.5) * 4 = 6\text{ V}$$

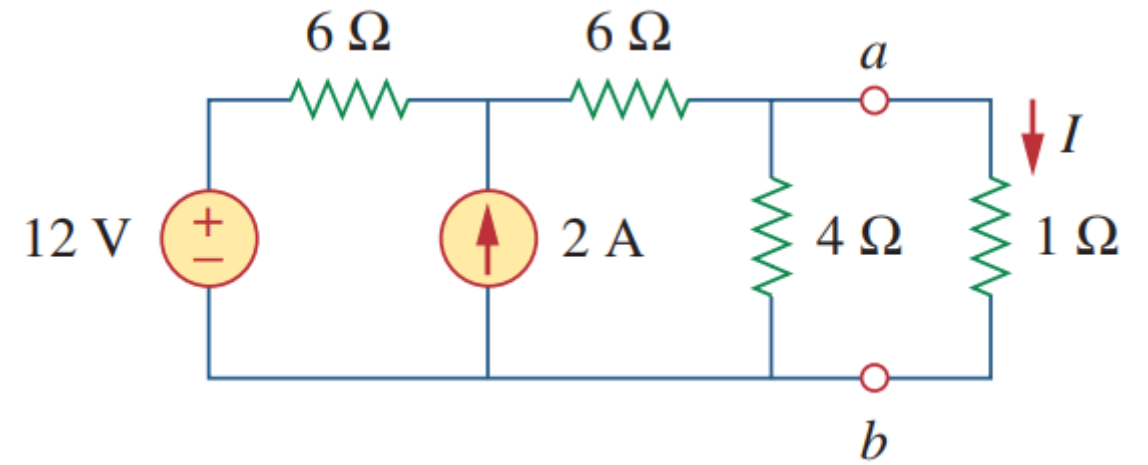

Electrical Circuit (1)

Norton's Theorem (week9 class2)

Dr. Akram Al-Mahrouk

Philadelphia University

Chapter 4 Circuit Theorems 127

- 4.1 Introduction 128
- 4.2 Linearity Property 128
- 4.3 Superposition 130
- 4.4 Source Transformation 135
- 4.5 Thevenin's Theorem 139
- 4.6 Norton's Theorem 145
- 4.7 †Derivations of Thevenin's
and Norton's Theorems 149
- 4.8 Maximum Power Transfer 150
- 4.9 Verifying Circuit Theorems
with *PSpice* 152
- 4.10 †Applications 155
 - 4.10.1 Source Modeling
 - 4.10.2 Resistance Measurement
- 4.11 Summary 160
 - Review Questions 161
 - Problems 162
 - Comprehensive Problems 173

Norton's Theorem

Norton's theorem states that a linear two-terminal circuit can be replaced by an equivalent circuit consisting of a current source I_N in parallel with a resistor R_N , where I_N is the short-circuit current through the terminals and R_N is the input or equivalent resistance at the terminals when the independent sources are turned off.

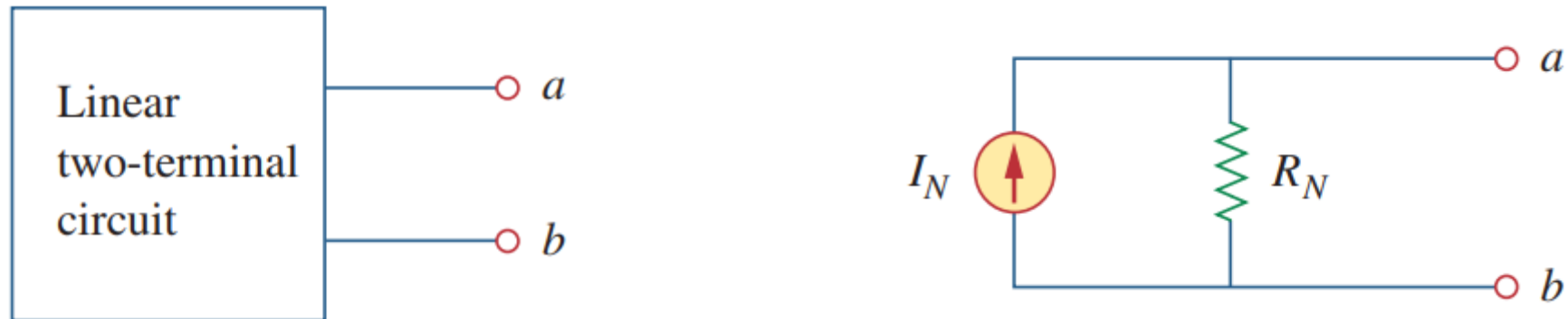

Norton's Theorem

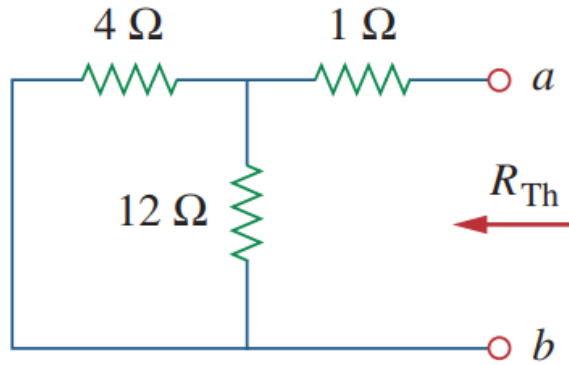
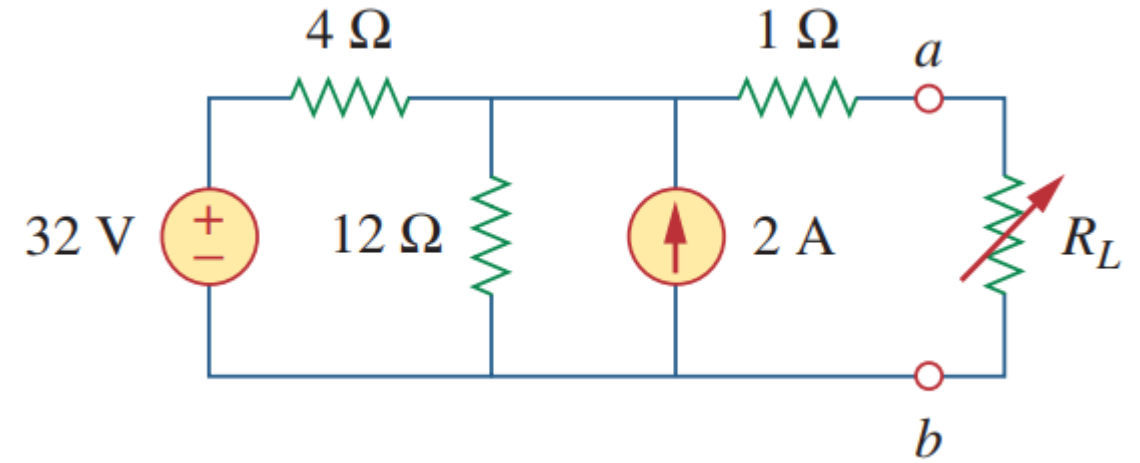

$$R_{th} = (4 || 12) + 1 = 4 \Omega$$

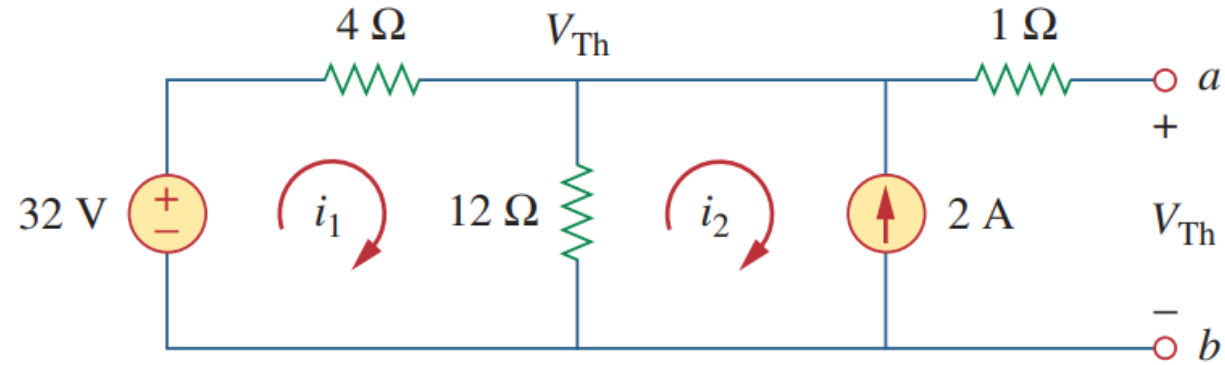

$$-32 + 4i_1 + 12i_1 - 12i_2 = 0$$

$$i_2 = -2A \quad i_1 = 0.5A$$

$$V_{th} = (0.5 - -2) * 12 = 30V$$

Norton's Theorem

Answer: $V_{Th} = 6\text{ V}$, $R_{Th} = 3\ \Omega$, $I = 1.5\text{ A}$.

$$R_{th} = (6 + 6) \parallel 4 = 3\ \Omega$$

$$-12 + 6i_1 + 6i_2 + 4i_2 = 0$$

$$i_2 - i_1 = 2$$

$$i_1 = -0.5\text{ A} \quad i_2 = 1.5\text{ A}$$

$$V_{th} = (1.5) * 4 = 6\text{ V}$$

